

FLYING ACES



Club

PLAN PACKET

NO. 1



FLYING ACES

3301 Cindy Lane
Erie, PA 16506

Dear Fellow FACers,

Here is your FAC Plan Packet #1. We hope you like it and will build some of the models therein. Remember though, that some of these plans were drawn back when the FAC Newsletter was very young (25 years ago) and the technical side of building and flying our models has changed rather drastically since then.

We now know more about thrust adjustments, rear motor peg locations, etc. so please use your own tried and true methods on these plans. Set them up in the way that works best for you.

We are giving you ten plans in this packet. Sixteen sheets (11 X 17) with nothing printed on the back sides so that you can build them right out of the packet.

Get to the workshop and.....

BUILD---FLY---Win-----EFF--AAA--CEEE!!!

Table of contents:

1. Golden Eagle Monoplane by Dave Stott 26 " span.
2. Westland Dreadnaught by Dave Stott 23" span.
3. Fokker F-XX by Dave Stott 28" span.
4. PZL P23A "Karas" by Pres Bruning 18" span.
5. Bristol 138A by Pres Bruning 18" span.
6. Tractable Trainer Embryo by Dave Stott 24" span.
7. Luscombe "Phantom" No-Cal bt Tom Nallen, Jr. 14" span.
8. Piper J-3 Peanut by Chet Bukowski 13" span.
9. Blackburn Sidecar Peanut by Frank Scott 13" span.
10. Caudron C.620 Peanut by Pres Bruning 13" span.

This Plan Packet Number One is dedicated to Dave Stott and Bob Thompson for the founding of the "Flying Aces Club" and its part in the resurgence of rubber powered scale modeling.

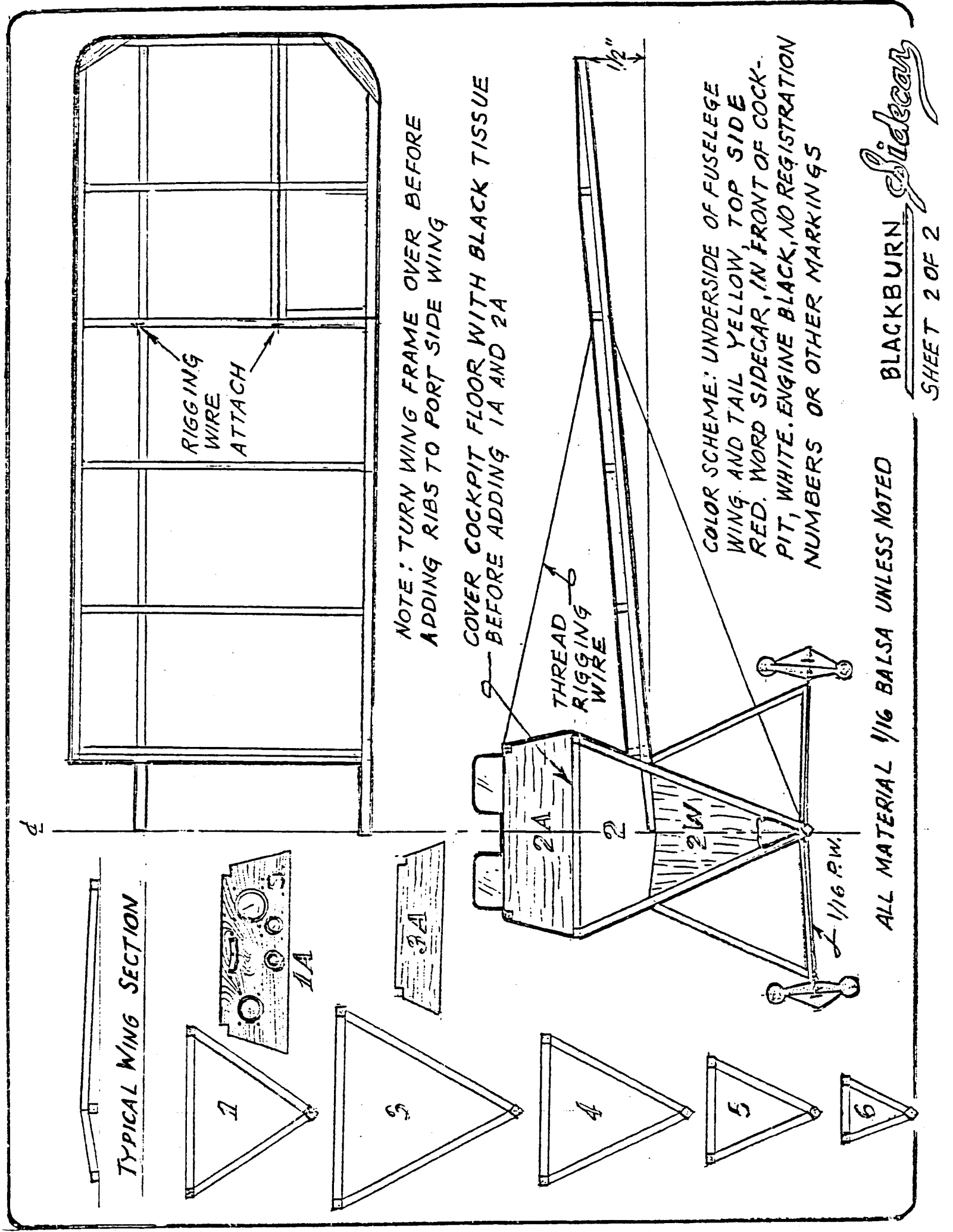
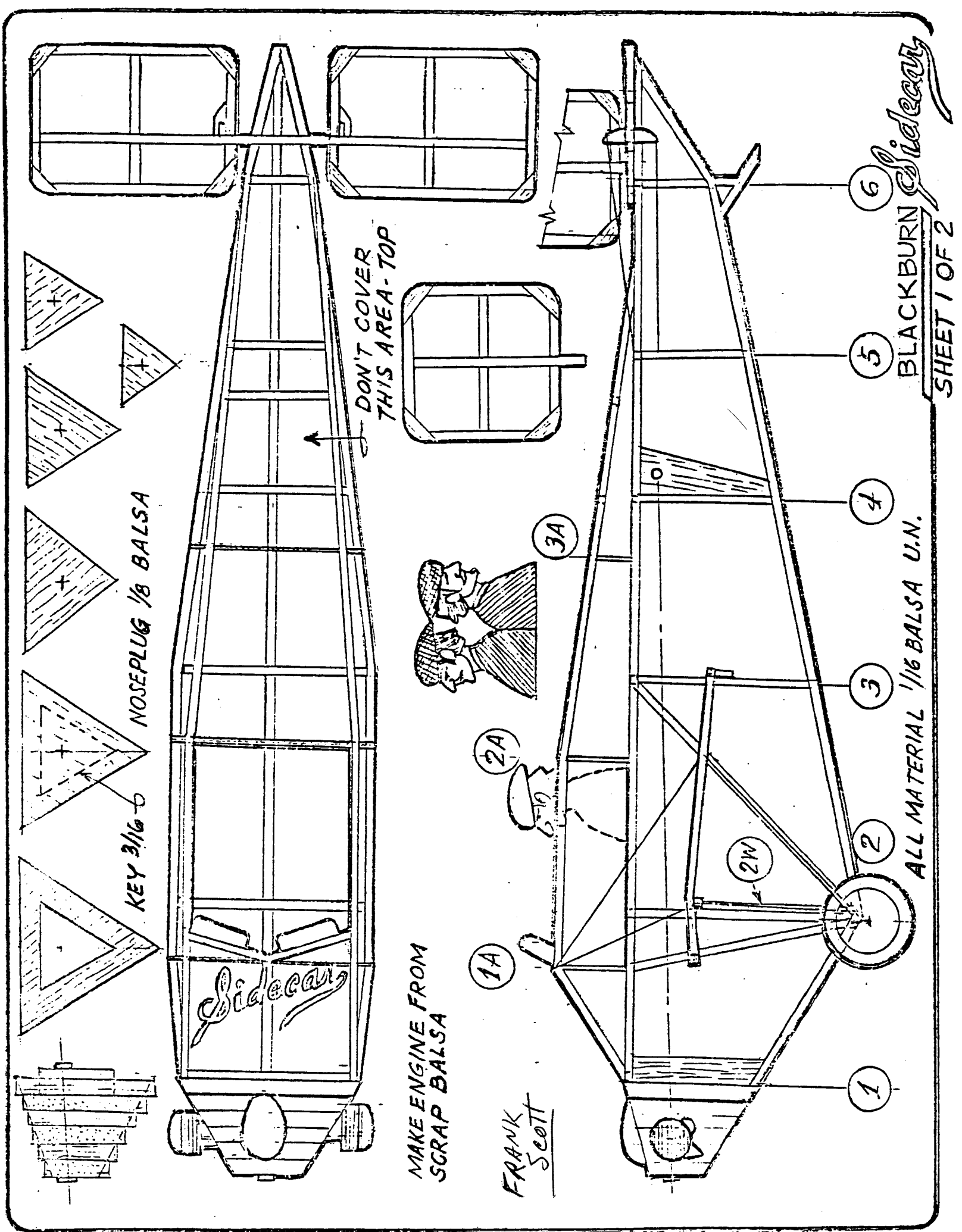

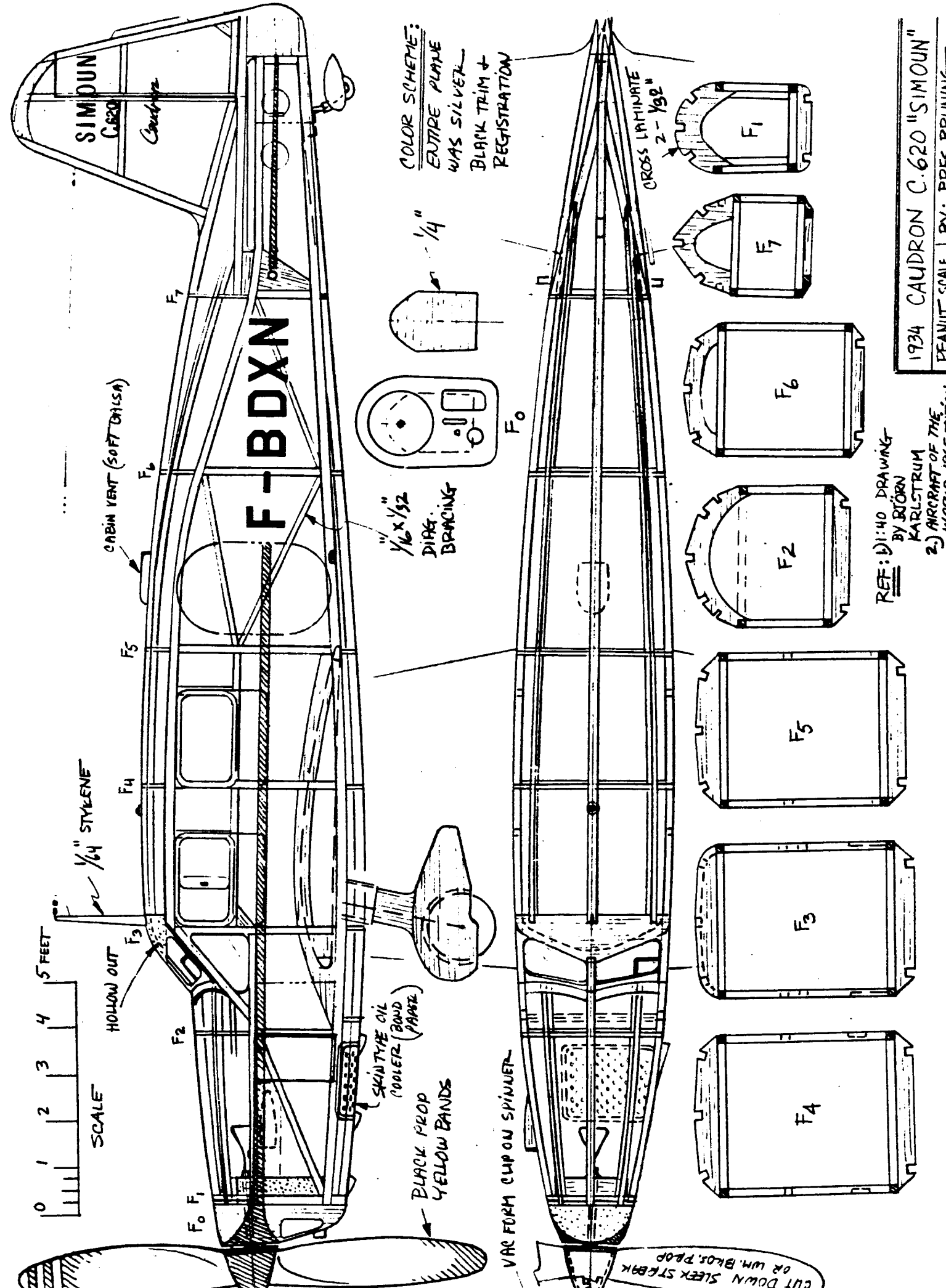
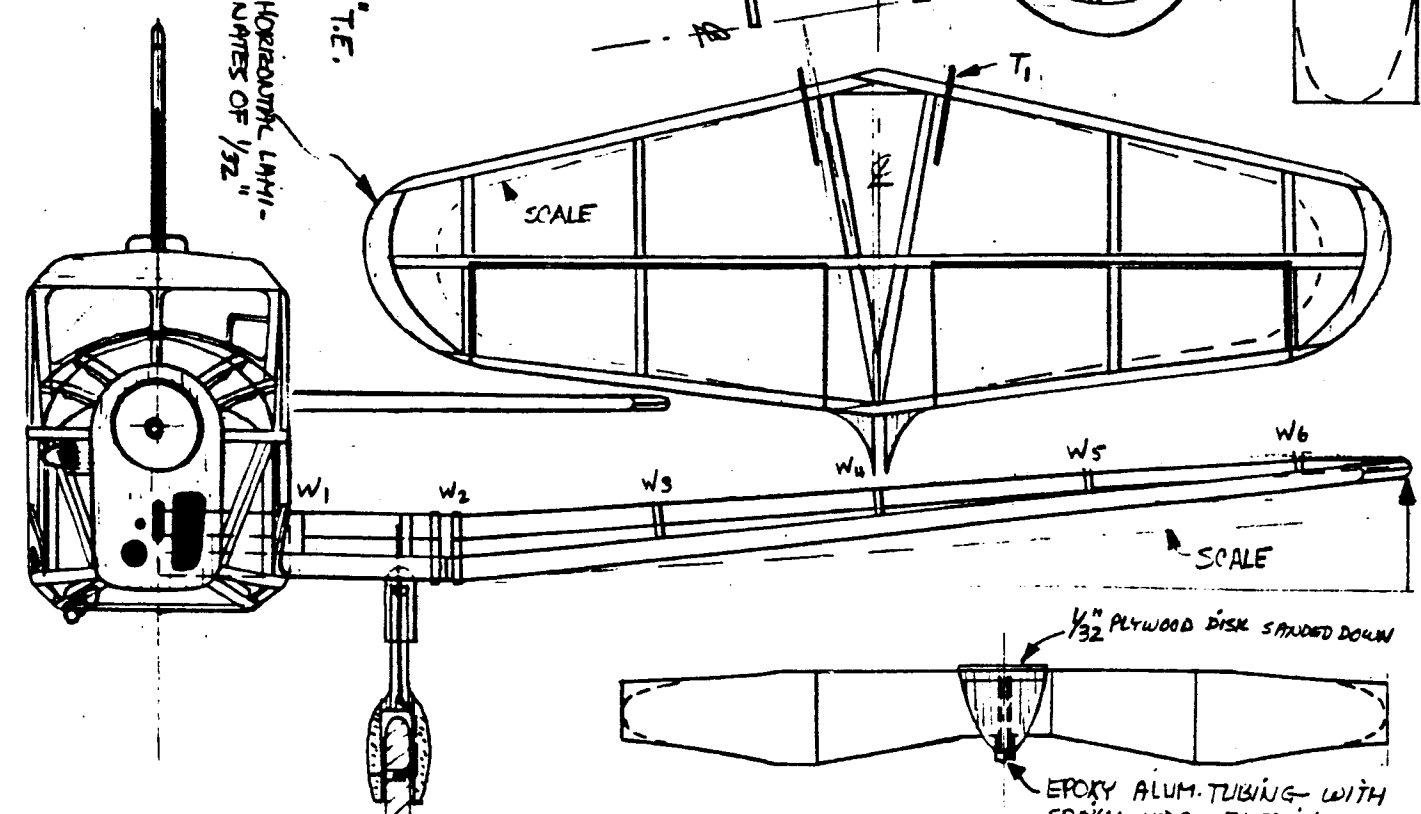
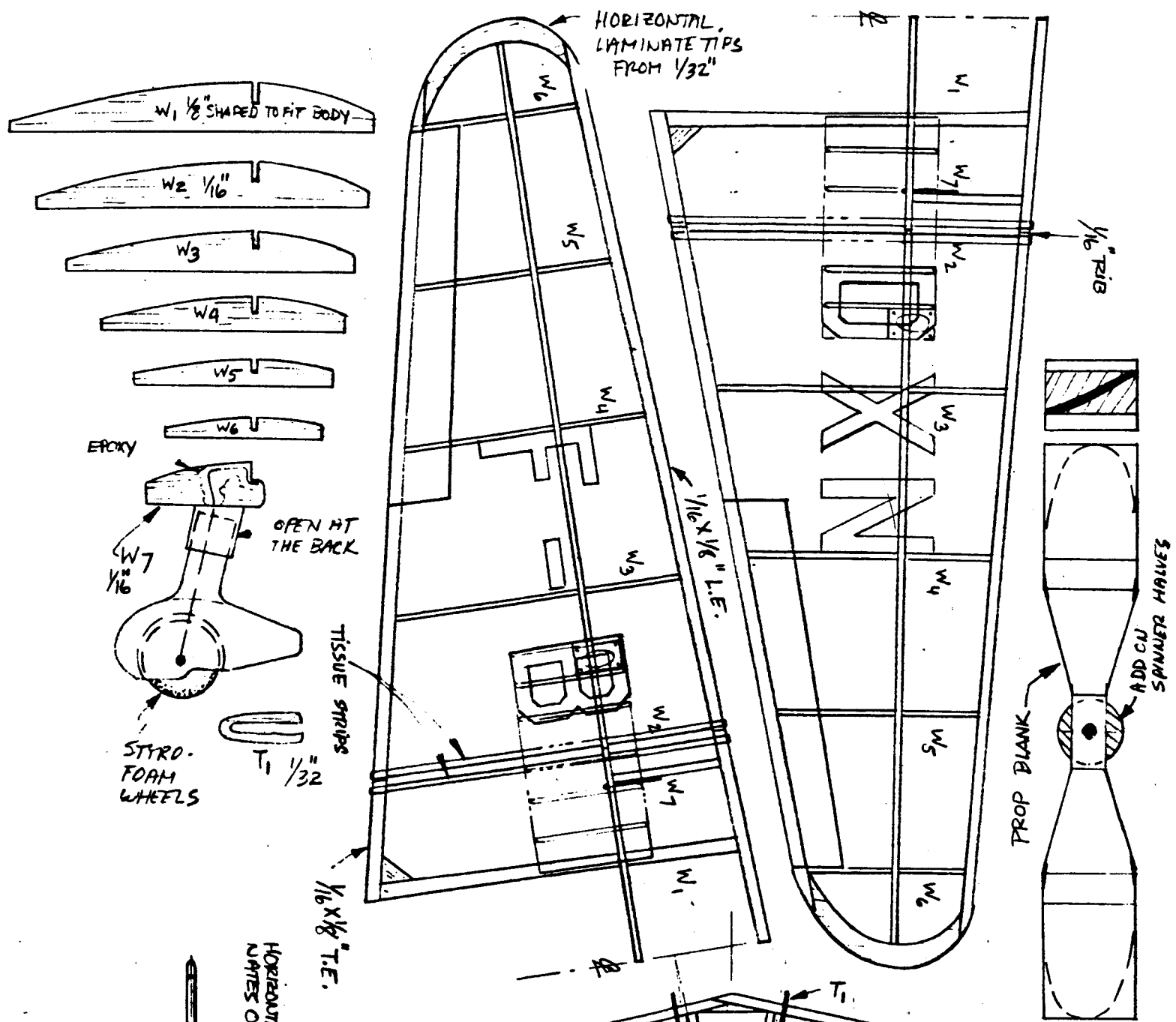

REF: 1) 1:40 DRAWING BY BROWN
2) AIRCRAFT OF THE WORLD 1965 EDITION
KARLSTROM

1934 CAUDRON C.620 "SIMOUN"
PEANUT SCALE BY: PRES BRUNING

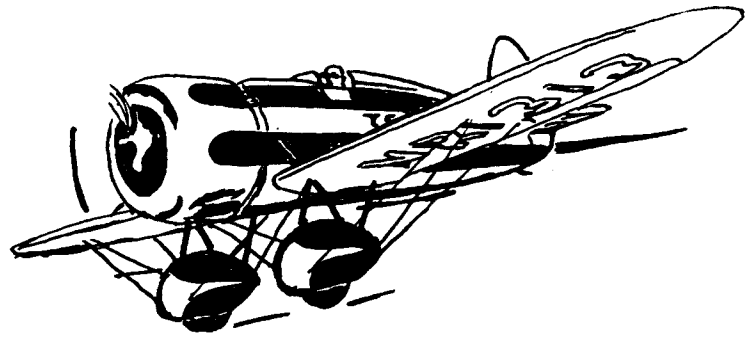

If you purchased this plan packet and you are not a member of the "Flying Aces Club" you can join by sending \$9.00 to: FAC, 3301 Cindy Lane, Erie, Pa. 16506.

This will get you on the membership list and entitle you to six issues of the newsletter and all rights and privileges of the "Flying Aces Club".

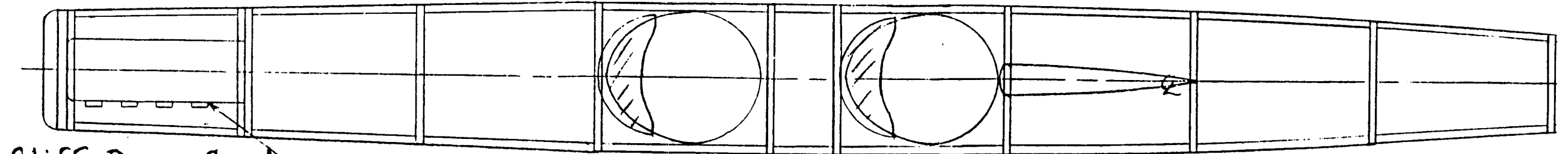
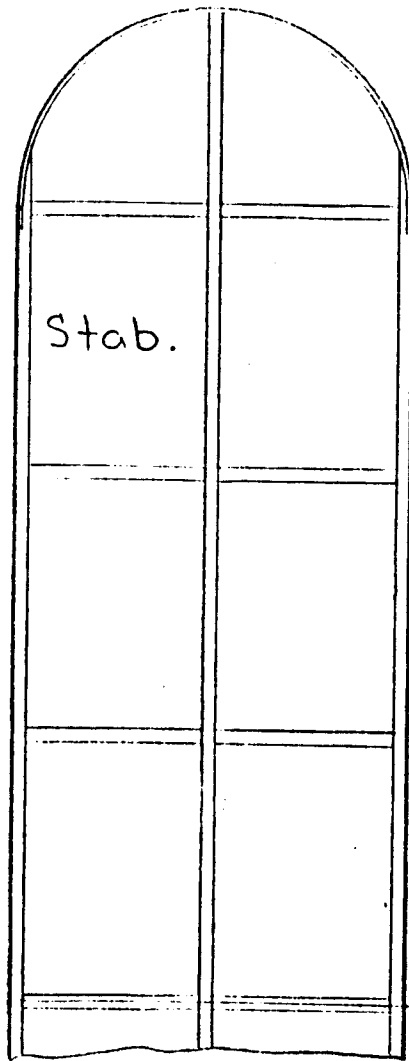
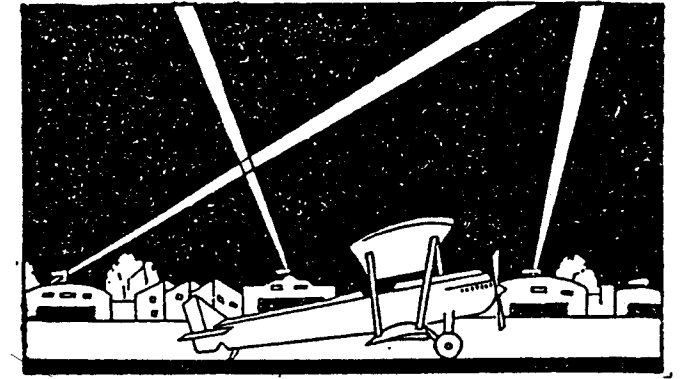

Stiff Paper Cowling

1/8 Dowel Exhaust Pipes

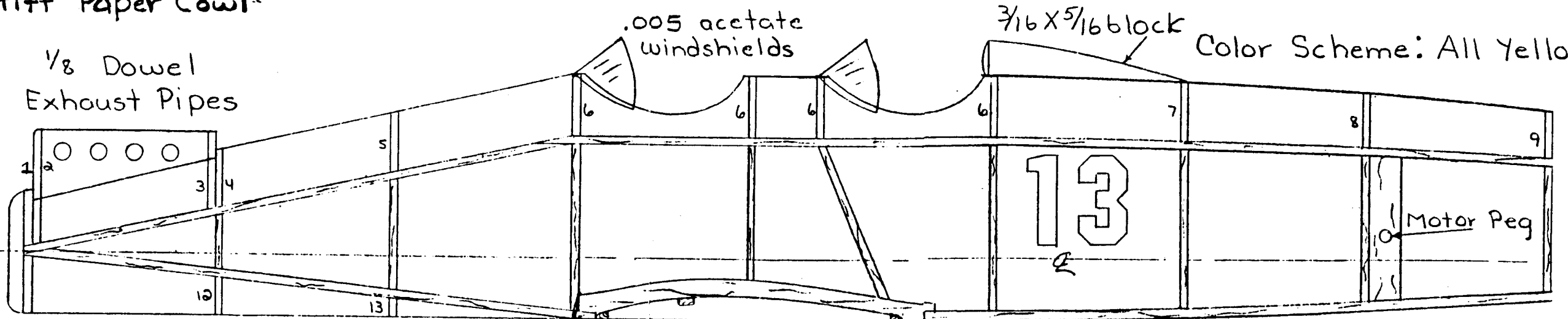

Color Scheme: All Yellow

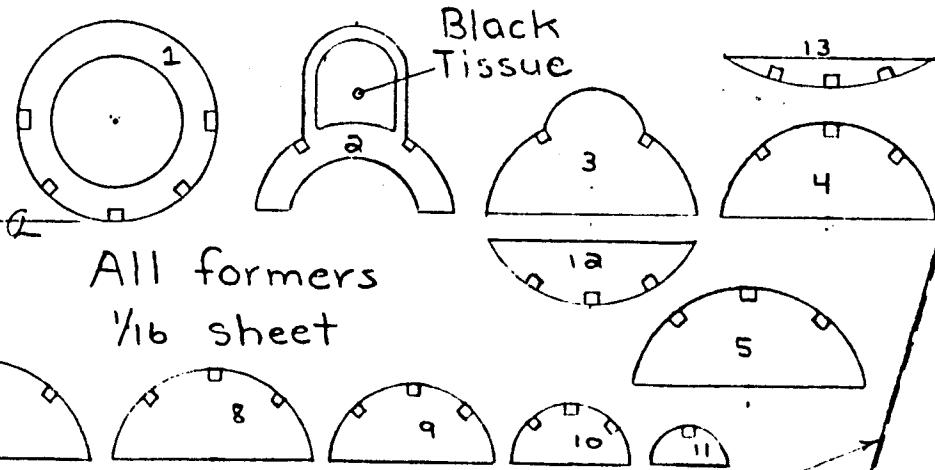

All formers 1/16 sheet



Bond Paper Dihedral 1 3/8 under tip rib

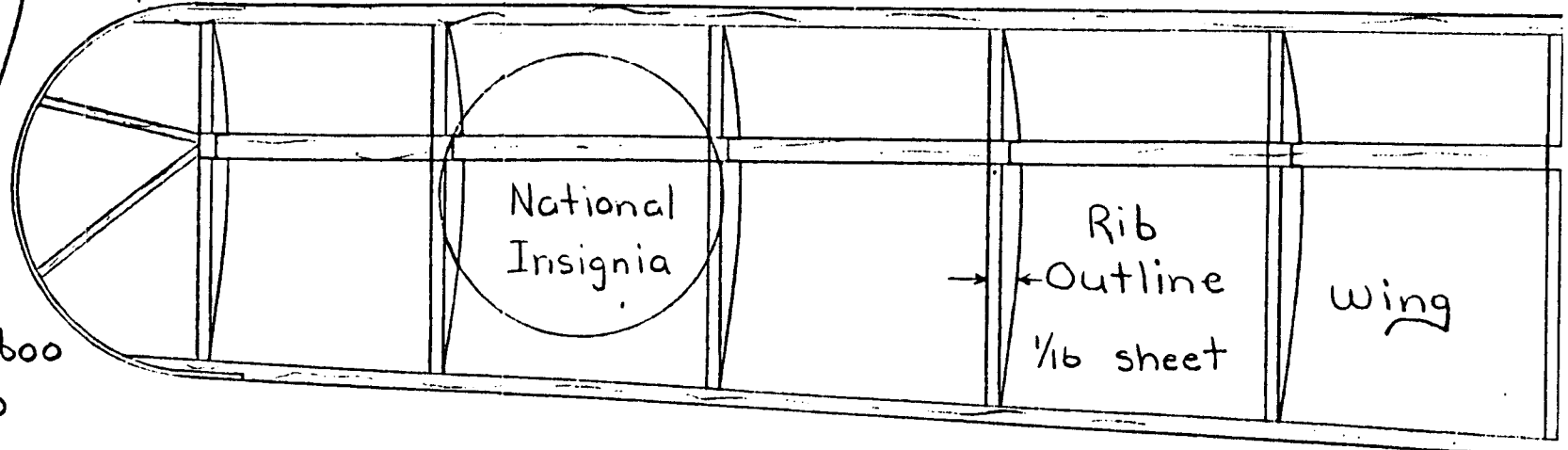

Rib Outline 1/16 sheet wing

THE FLYING ACES TRACTABLE TRAINER

lettered Chet by: Whiteley

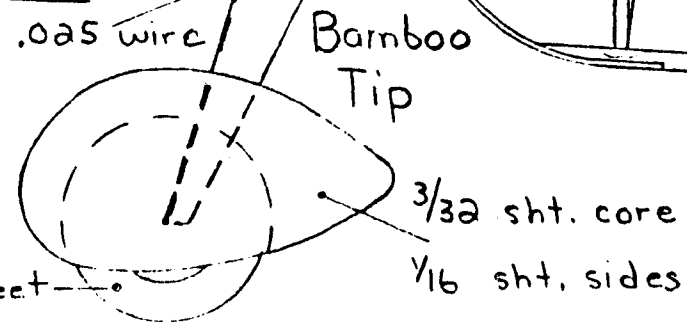

1/16 sheet

3/32 sht. core 1/16 sht. sides

Prop. Block, 1/2 x 3/4 x 8

3/32 x 1/16 T.E

FOKKER F.XX TRANSPORT

by Dave Stott

Blue area inside triangles
bottom surface of STAB only.

By turbulence fellas, here are plans to the great ship of that designing Dutchman, Tony Fokker. And for a one of airplane (as our English cousins would say) it led a pretty speckled career in both the civil transport role, and as a bomber in the Spanish Civil War. Our plan depicts the F.XX "Silvermeeuw" in civil markings as operated by K.L.M. Royal Dutch Airlines.

A blue and silver beauty, this ship will make a worthy addition to your model hanger, or by turbulence let HUNG strike us pink! In the estimation of the gang here at GHQ, this is by far the sleekest of all tri-motors to take to the ozone! Fully retractable landing gear, rakish of line! What more could a rib slicin' tissue trimmer ask for?

As most of our Clubsters are accomplished builders, we will not go into much detail in the construction aspect of this Fokker. We all have our pet methods, and as far as power and prop goes, we all build as differently as our finger prints, so our selection of power and prop is dependant on our individual whims. And with that oral slipstream, we will say no more.

The model was built by the "Milford Fox", Bob Jespersen, and a fine looking machine she is! Of average weight, she took less power than expected, probably due to her clean lines. Further tests proved her easier to trim with a scale size rudder, rather than the oversize one fitted at first.

Better head for the workshop, Skysters an "Amsterdam good time" as the TV K.L.M. add says.

THE BRISTOL 138A

By Pres Bruning

In 1936, this long winged pride of the Empire captured for England the world's altitude record piloted by F.R.D. Swain. The new mark was 49,967 feet! Over nine miles! No simple task in those days.

As can be seen in Pres's plan for the model, the pilot wore a sort of deep sea divers outfit to protect him from the low pressure at high altitudes. Rather like the outfit worn by Wiley Post.

Pres's model is drawn to Walnut Scale proportions. He also mentions that a Jumbo Scale model of this ship ought to be interesting as well. We heartily agree, Pres! She looks like a natural to the Gang here at GHQ. Any of you dare devils of the drafting board allergic to Walnuts, just whip out your dividers and double up on this neat job or take it to your local copier center and have it doubled.

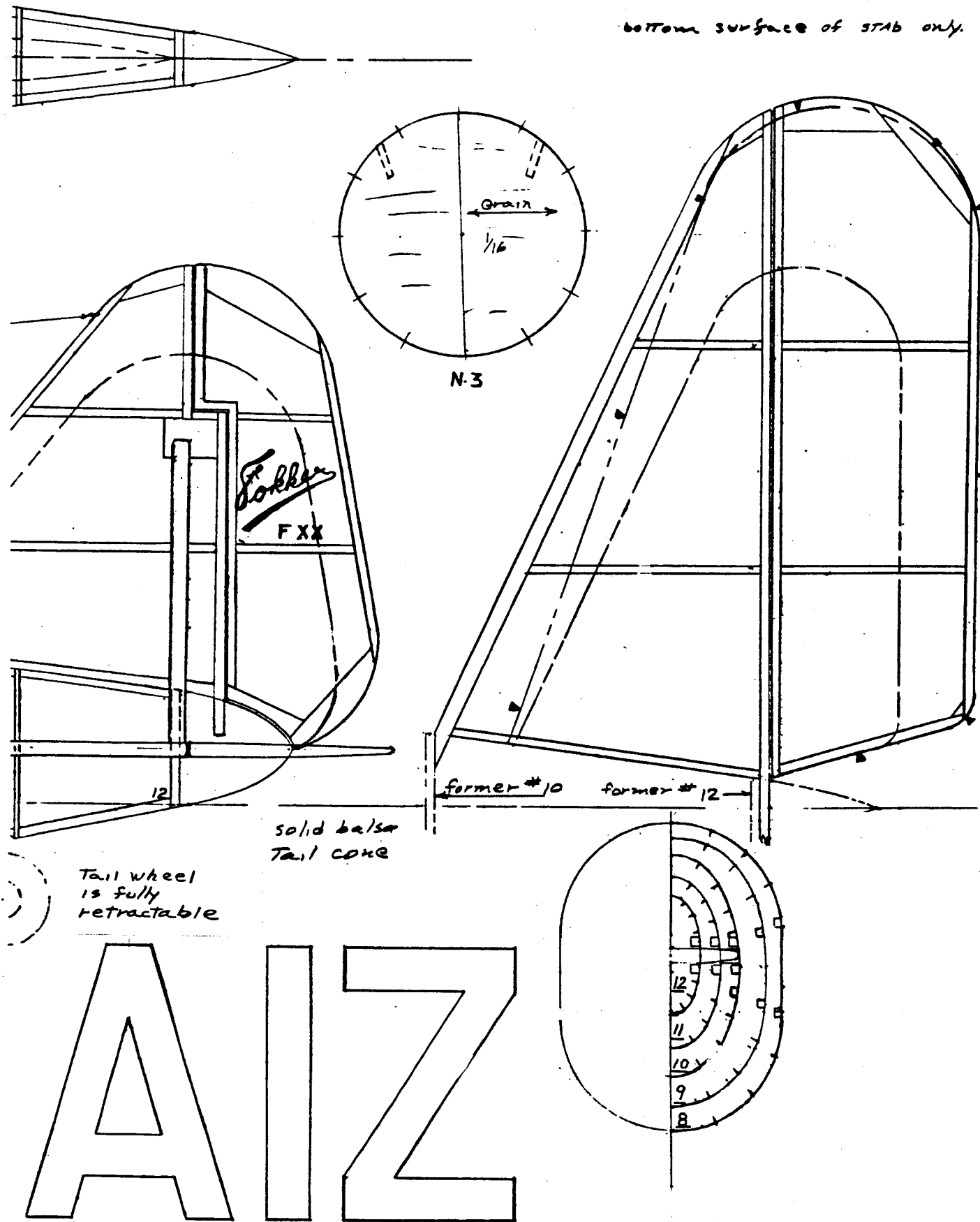

Registration Lettering for Wing

Tail wheel is fully retractable

solid balsa Tail cone

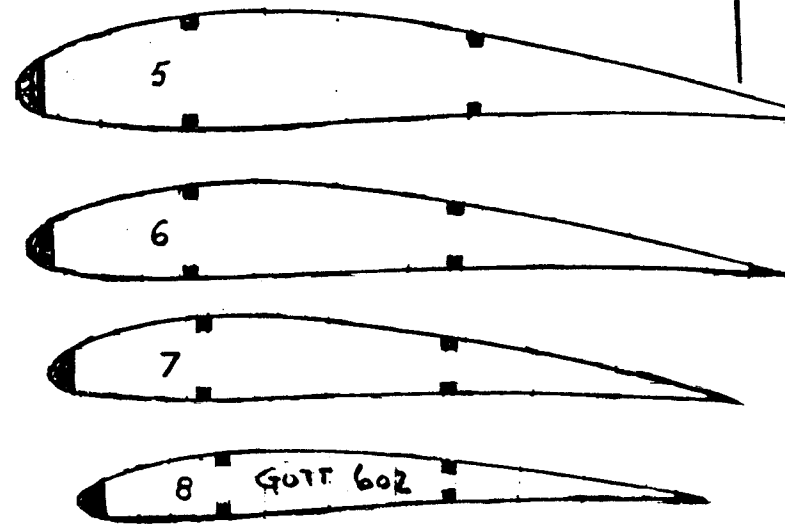
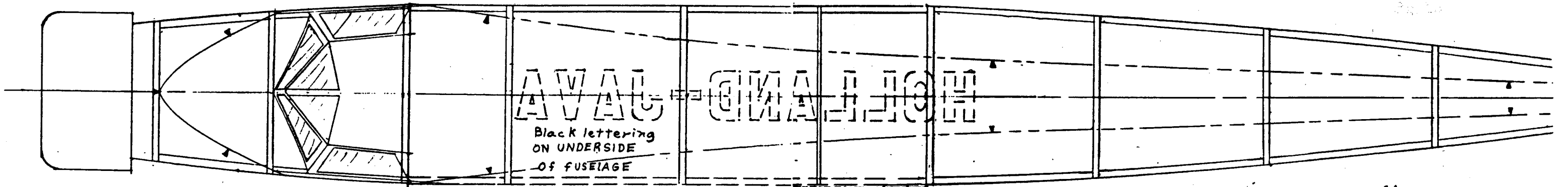

References:
 "Fokker - The Man and the Aircraft"
 By HENRI HEGERER
 "LA AVIACION EN LA GUERRA DE ESPAÑA"
 Vol. 3 by SALVADOR RELLO

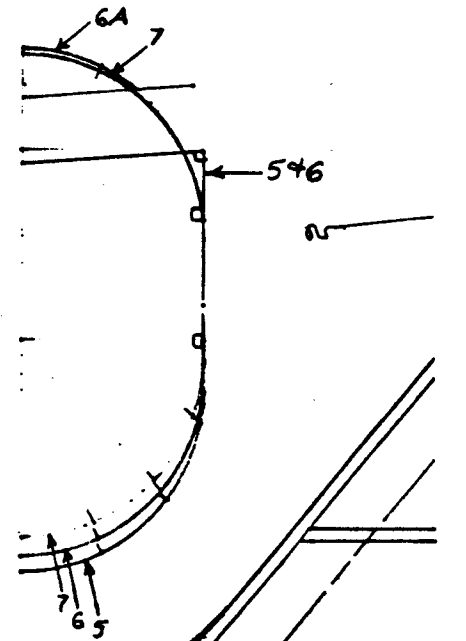
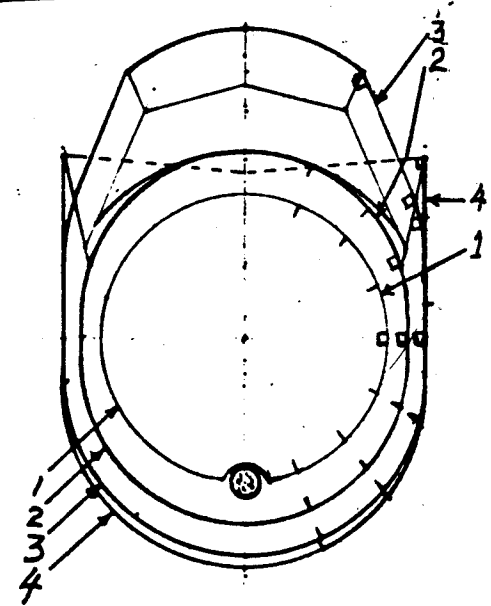
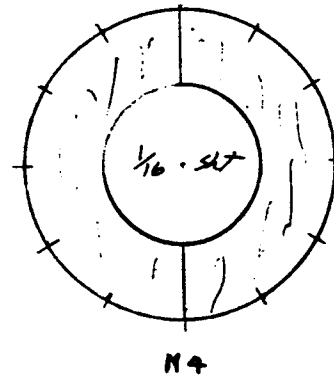

ANTEN.

GÖTT. 413 at root
 To GÖTT. 602 at TIP

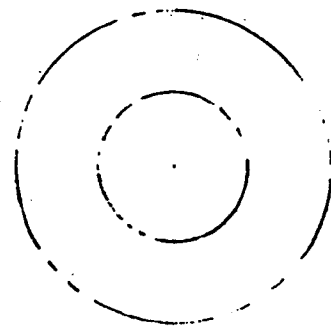
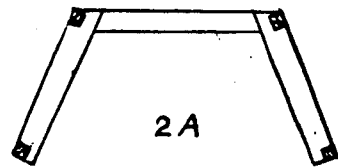
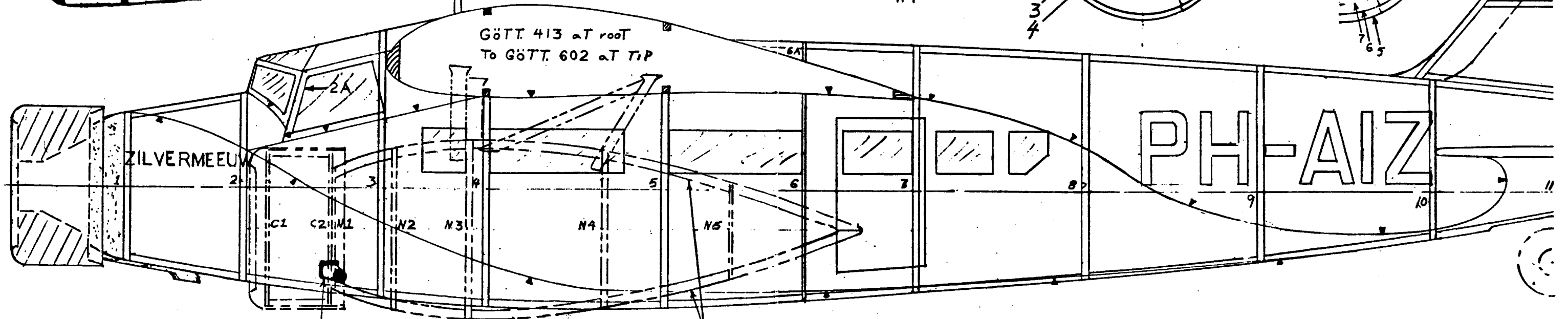

L.G. is fully retractable

N6
24 req'd

Area inside of Triangles A is blue.
 All engine cowlings are blue.
 Basic color of aircraft is silver.
 All struts are silver.
 All lettering is black.
 Engine nacells are silver.

A FLYING club Plan

8.2.29 '69

FOKKER FXX of K.L.M.

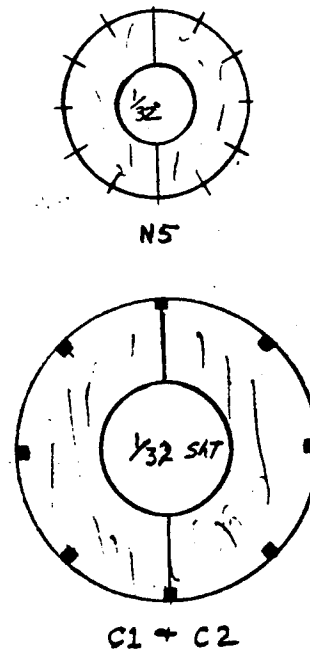
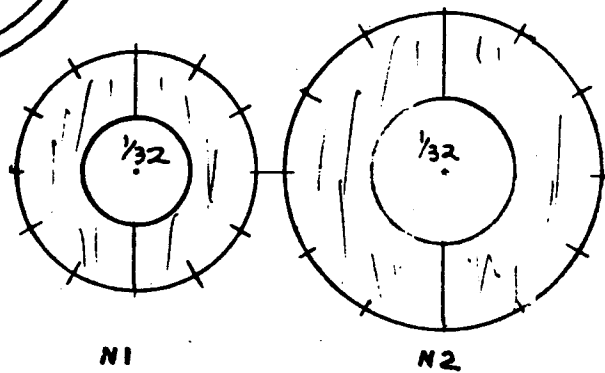
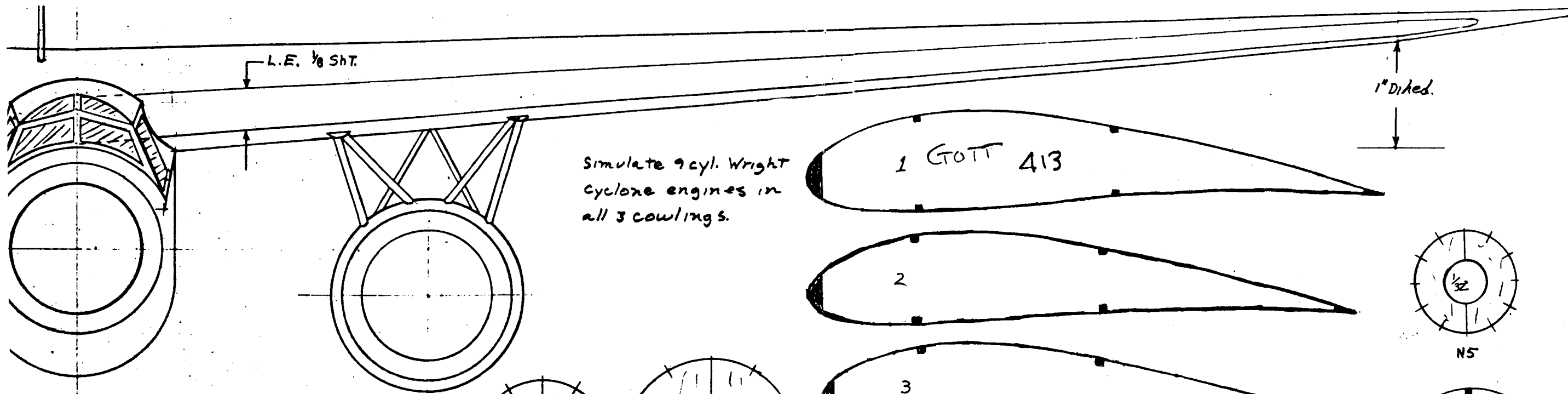

"PH-A1Z" in black letters
Top & bot. of wing. "Z" same
distance from tip as "P"

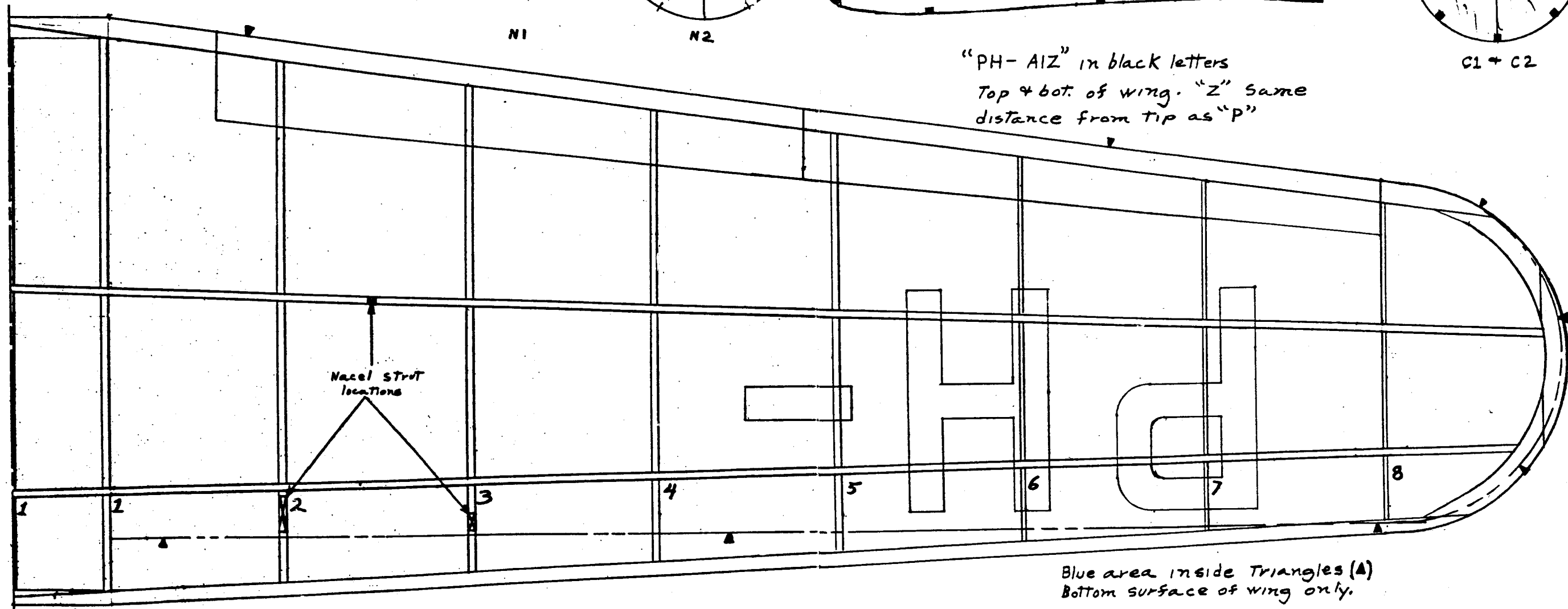

THE GOLDEN EAGLE MONOPLANE

BY DAVE STOTT

This snazzy lookin' sky cruiser was designed by Mark M. Campbell and built by the R.O. Bone Co. of Inglewood, Ca. back in 1929. Just in time for the stock market crash to spin it in, alas!

Powered by a 60 H.P. Velie, this two-placer spanned 30 feet plus 6 inches of Clark Y wing. Length was 21 feet.

According to Aero Digest, this crate had wings finished in silver or gold while the fuselage and tail would be finished in any color desired. We can only wonder if the stabilizer was finished as was the wing, or was that done the same as the fuselage? Probably as the wing we'd bet. The photo published in Aero Digest (registration X-10071) seems to have been colored as descibed on the model plan. At least it seems more appropriate for X-10071.

Many of you former notchers will notice this crate has proportions for tough competition like a Miss America winner. Sure it will take a little time to build up a swell looking dummy Velie engine, but isn't that why you are a scale modeler?

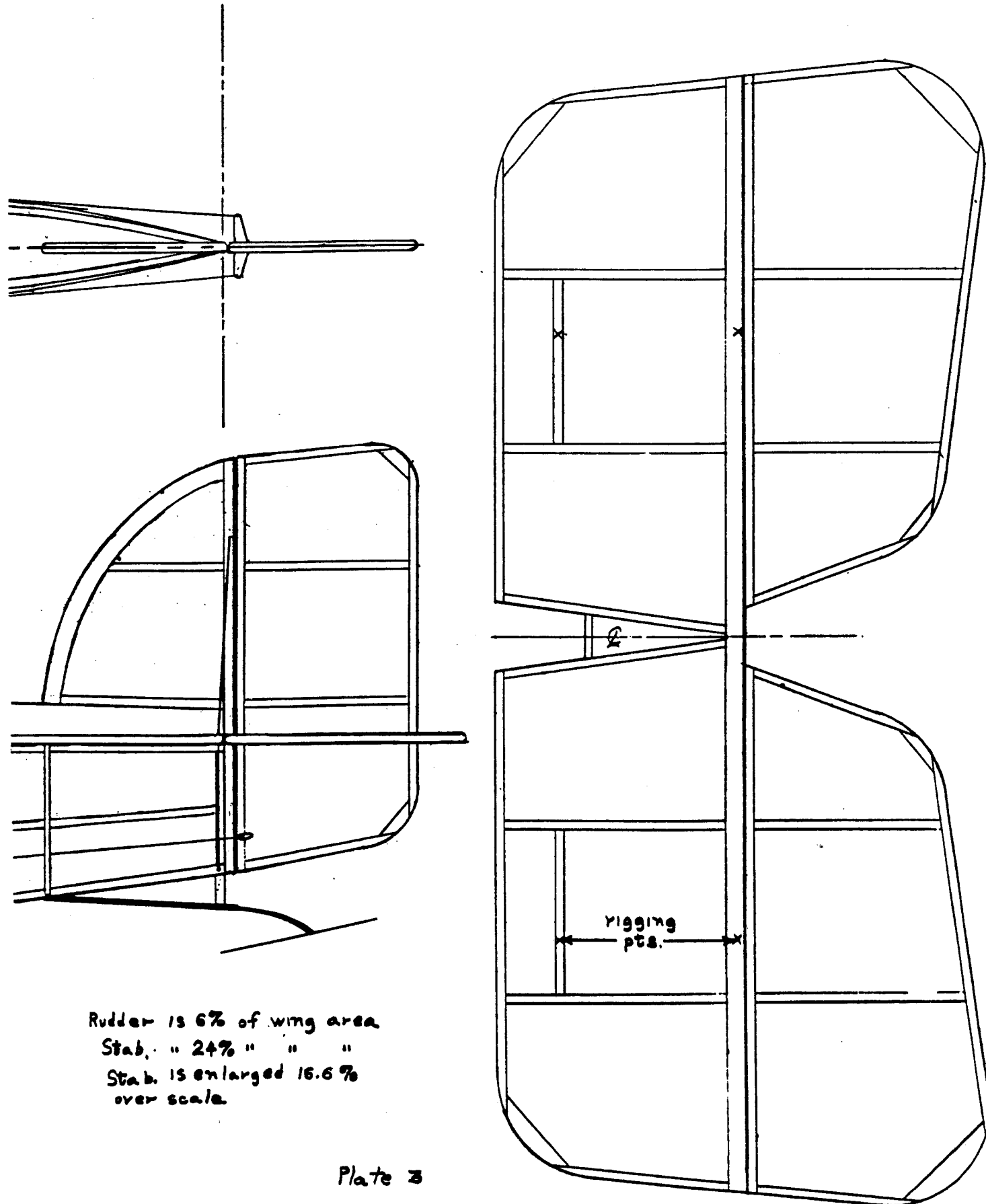

Rudder is 6% of wing area
 Stab. " 24% " " "
 Stab. is enlarged 16.6%
 over scale.

Plate 3

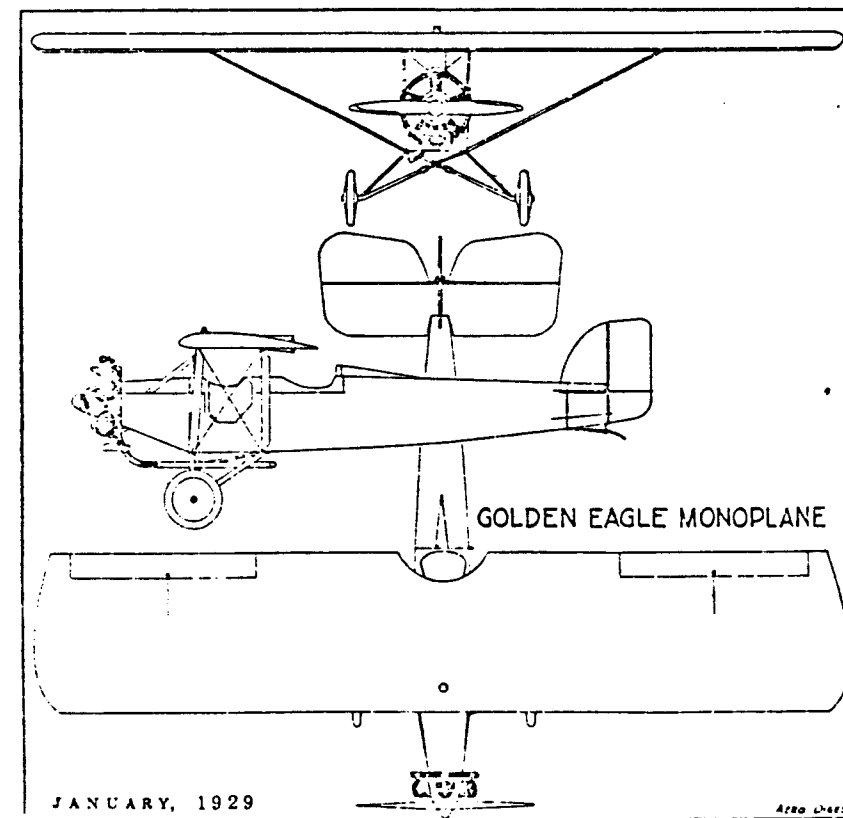

Scale outline drawings of the Velie-engined Golden Eagle monoplane

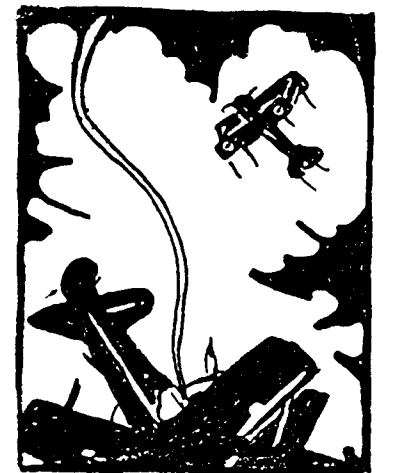

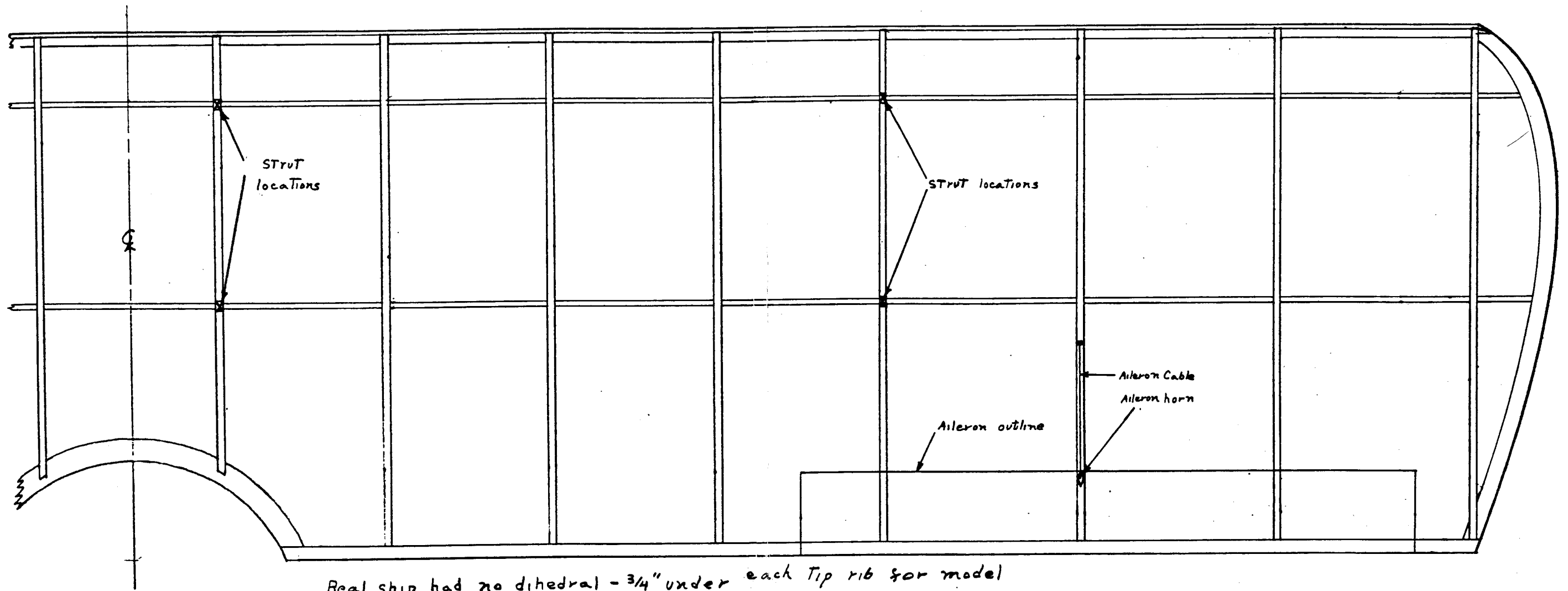

Real ship had no dihedral - 3/4" under each Tip rib for model

Plate 4

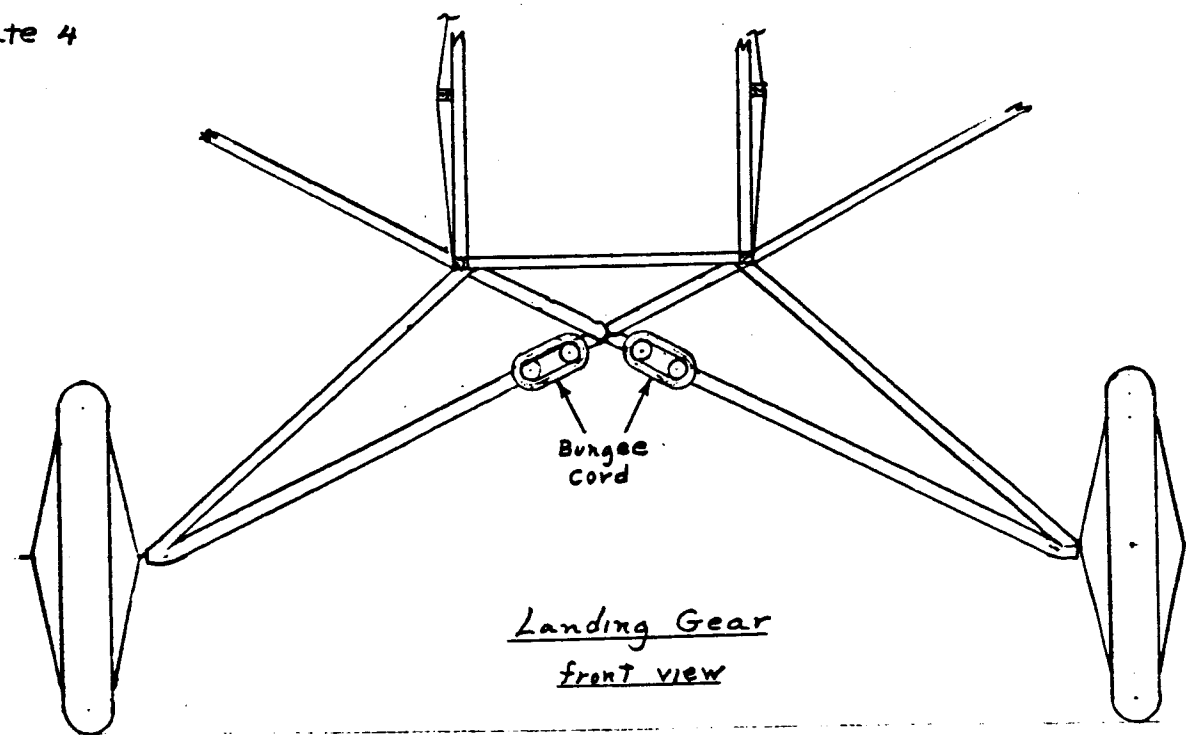

Eng. details

Plate 5

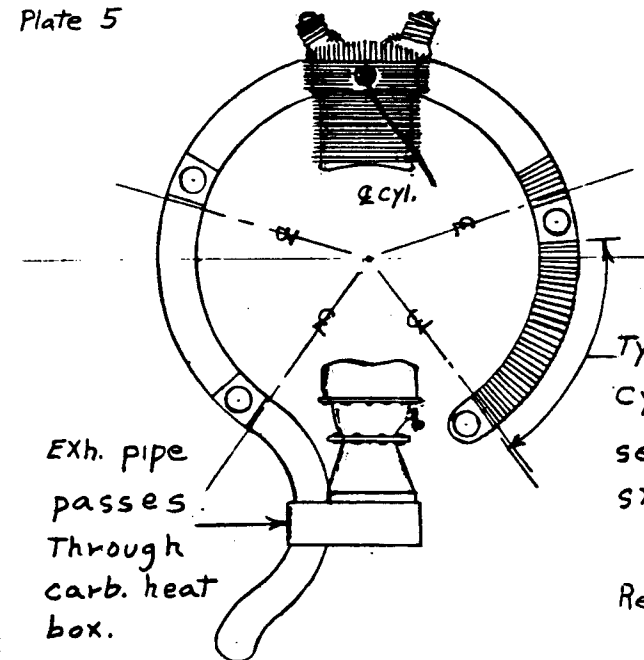

X-10071



GOLDEN EAGLE MONOPLANE

Typ. between each cyl. outlet pipe sect. which was smooth as shown.

Rudder markings - Eagle - white Printing and registration - black

Reg. also on wing in 2 1/2" x 1 1/2" blk. letters Top of right wing - bottom of left.

Wheels & all struts
were gloss black.

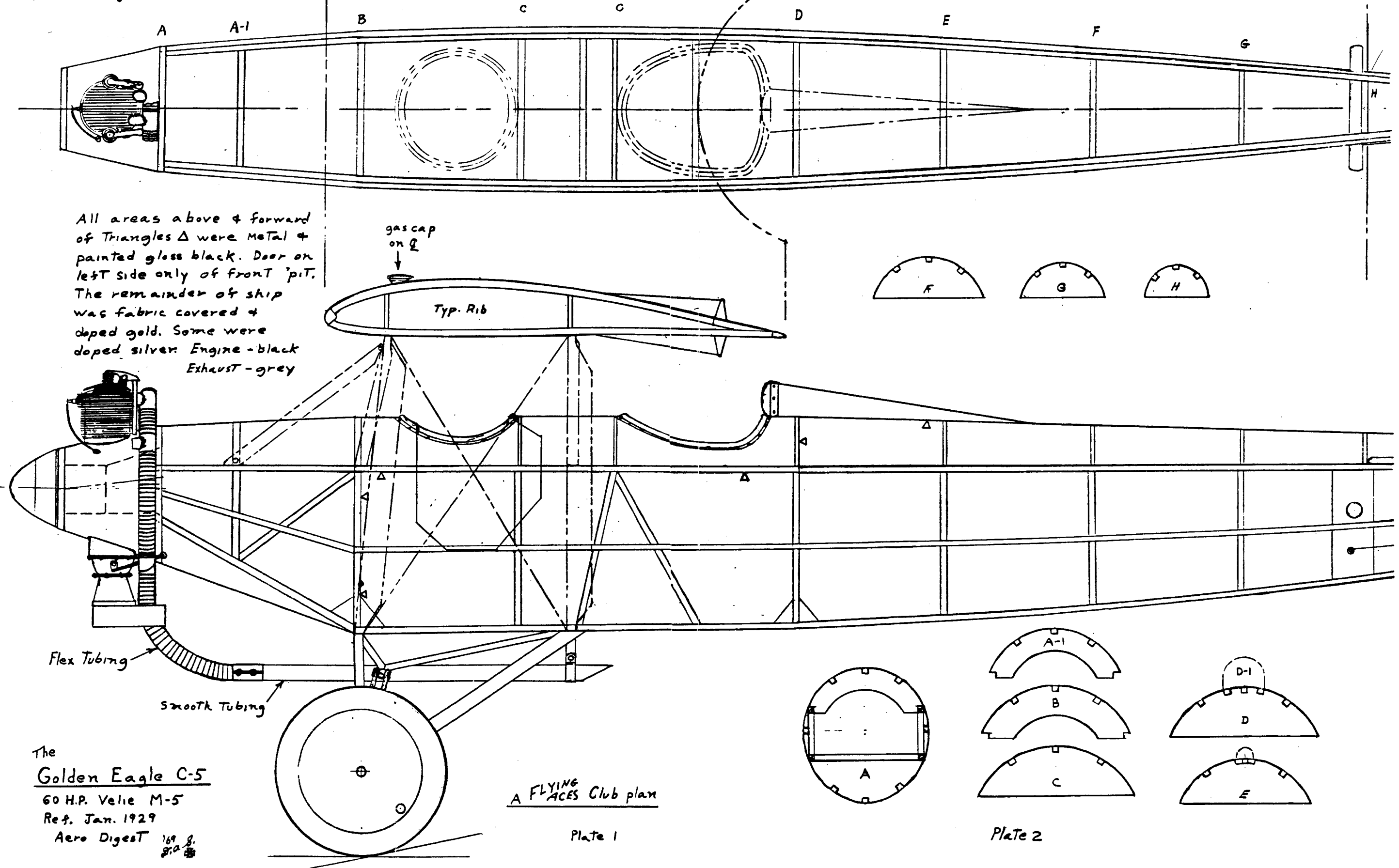

All areas above & forward
of Triangles Δ were metal &
painted gloss black. Door on
left side only of front pit.
The remainder of ship
was fabric covered &
doped gold. Some were
doped silver. Engine - black
Exhaust - grey

The
Golden Eagle C-5
60 H.P. Velie M-5
Ref. Jan. 1929
Aero Digest 169 p.
8/2

A FLYING
ACES Club plan

Plate 1

Plate 2

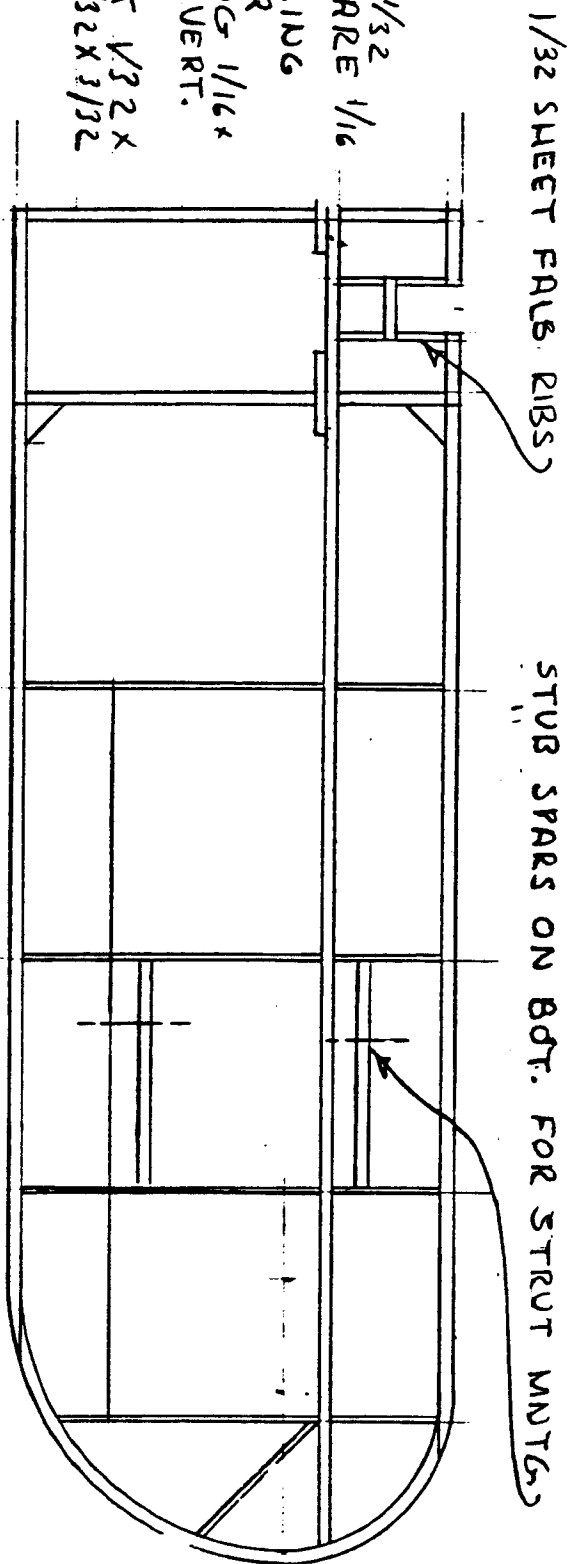

RIBS ARE 1/32
 ROOT RIBS ARE 1/16
 SPAR & TRAILING
 EDG 1/16 SQ
 LEADING EDG 1/16 x
 1/8 PLACED VERT.
 FRONT STRUT 1/32 x
 1/8, REAR 1/32 x 1/32

NOTE: KEEP TOP OF WING FLAT

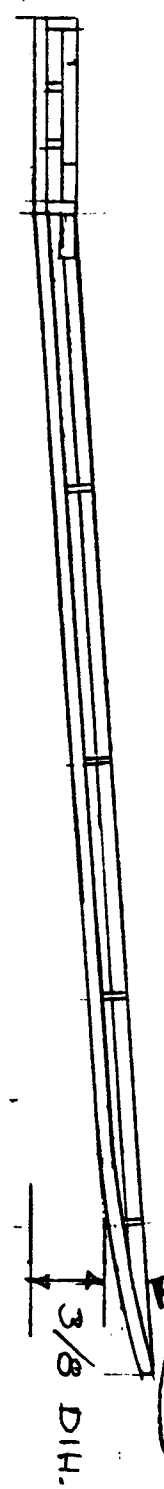

TRIM: TAIL SURFS...
 ARE SPOT-GLUED IN
 PLACE - CUT FREE
 & RE SPOT GLUE FOR
 ADJ. SET RUDDER
 SLIGHT RIGHT (VERY)
 USE RT. THRUST FOR POWER
 CIR. + DOUBLE THRUST AS REQ.

TIPS ARE LAMINATED
 FR 2 PIECES OF 1/32
 x 1/16

1/32 x 1/16
 FROM SPAR TO TIP BOW

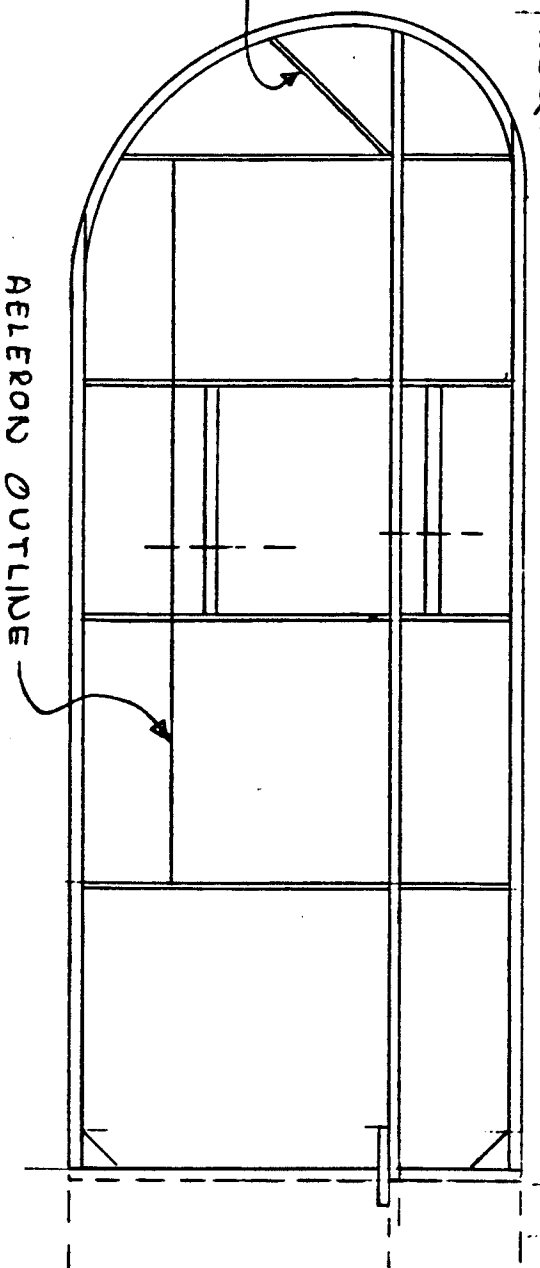

AILERON OUTLINE

NOTE: BUILD WING IN ONE PIECE
 WITH DIHED. COVER BOT. PANELS
 AND FUS. SIDES AND BOT, MOUNT
 WING ON FUS. ADD TOP STRINGER
 & COVER FUS. TOP & WING TOP

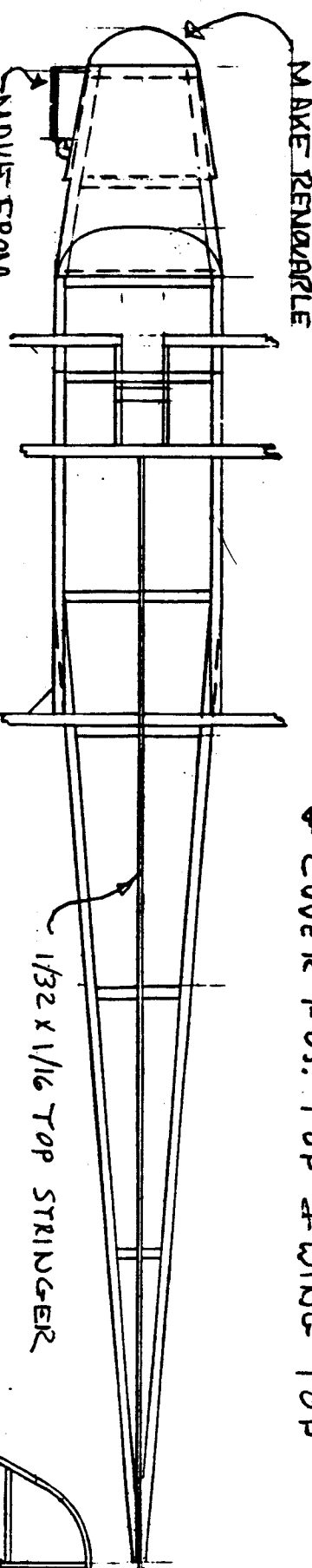

MAKE REMARKLE
 3/16 SQ CORNERS RND.
 THRD. CIL. FINS PAPER COLLIDG SHEPS.

1/32 x 1/16 TOP STRINGER

BRACE FOR STAB LIE

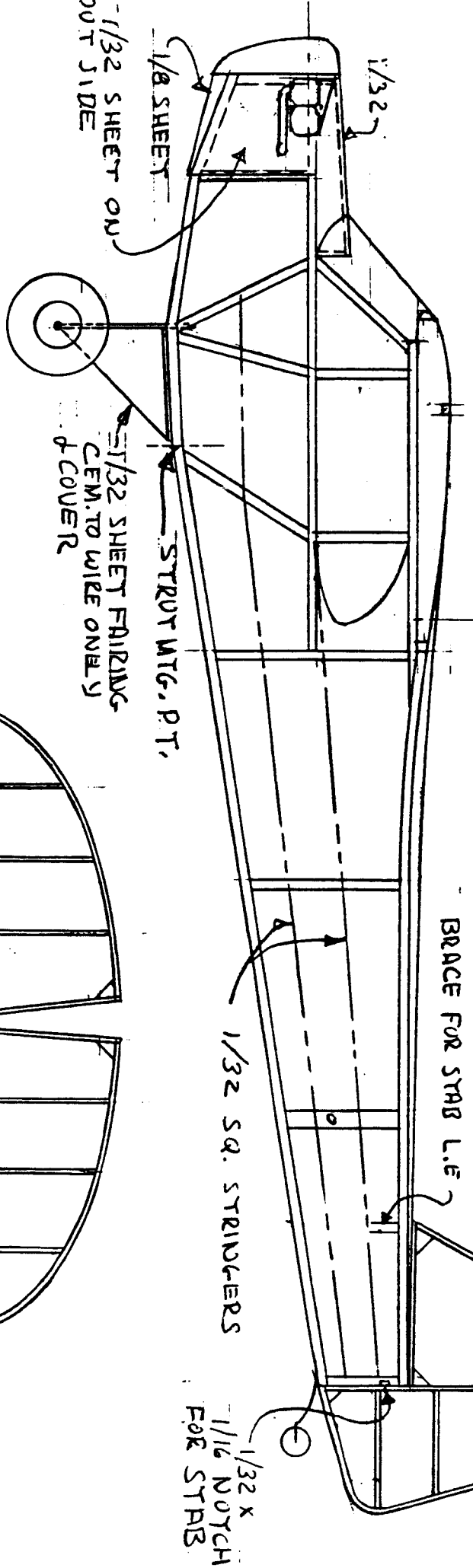

1/32 SHEET ON
 OUT SIDE

1/8 SHEET

1/32 SHEET FAIRING
 CEM. TO WIRE ONLY
 & COVER

STRUT MTG. PT.

1/32 SQ. STRINGERS

1/32 x
 1/16 NOTCH
 FOR STAB

TAIL SURF. OUTLINES ARE MADE
 FROM 1/32 SQ WED. HARD, TOUGH,
 STRINGY WOOD FORMED WET ON
 CARDBOARD FORMS THEN BAKED FOR
 15 MIN. IN LOW OVEN @ 150-200 F.

PIPER J-3 CUB BY CHET BUKOWSKI

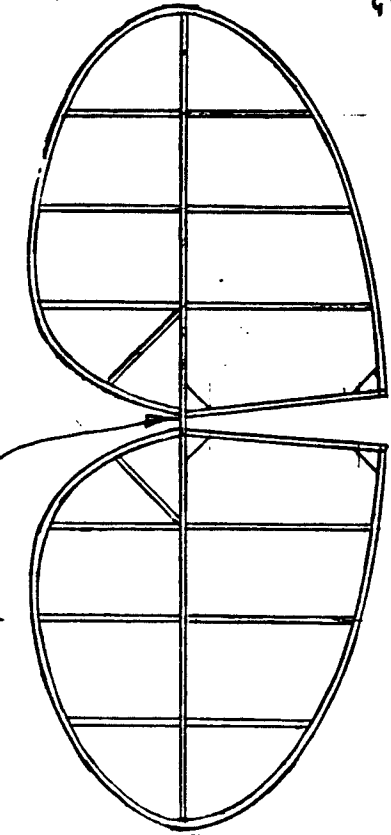

ADD 1/32 SQ
 DOUBLER AFTER COVER

SCHEMATIC

PZL P23A "KARAS"

Designed for close support of Polish Army troops, the Karas (Crucian-carp) was powered by a Skoda built Bristol Pegasus. The craft Pres Bruning has drawn up belonged to #55 Squadron, Bomber Brigade and saw action during September 3 to 8, 1939.

Although Pres has included the color scheme on the plan, and shows the Bulgarian version, complete coloring and marking for Bulgarian, Roumanian, and Polish Air Force craft are to be found in Profile Publication #104. Judging from the contented smiles on the pusses of the flyers on the model plan it must be pre-September, 1939. This should make a very interesting World War Two subject. Never been built, to our knowledge. Go for it!

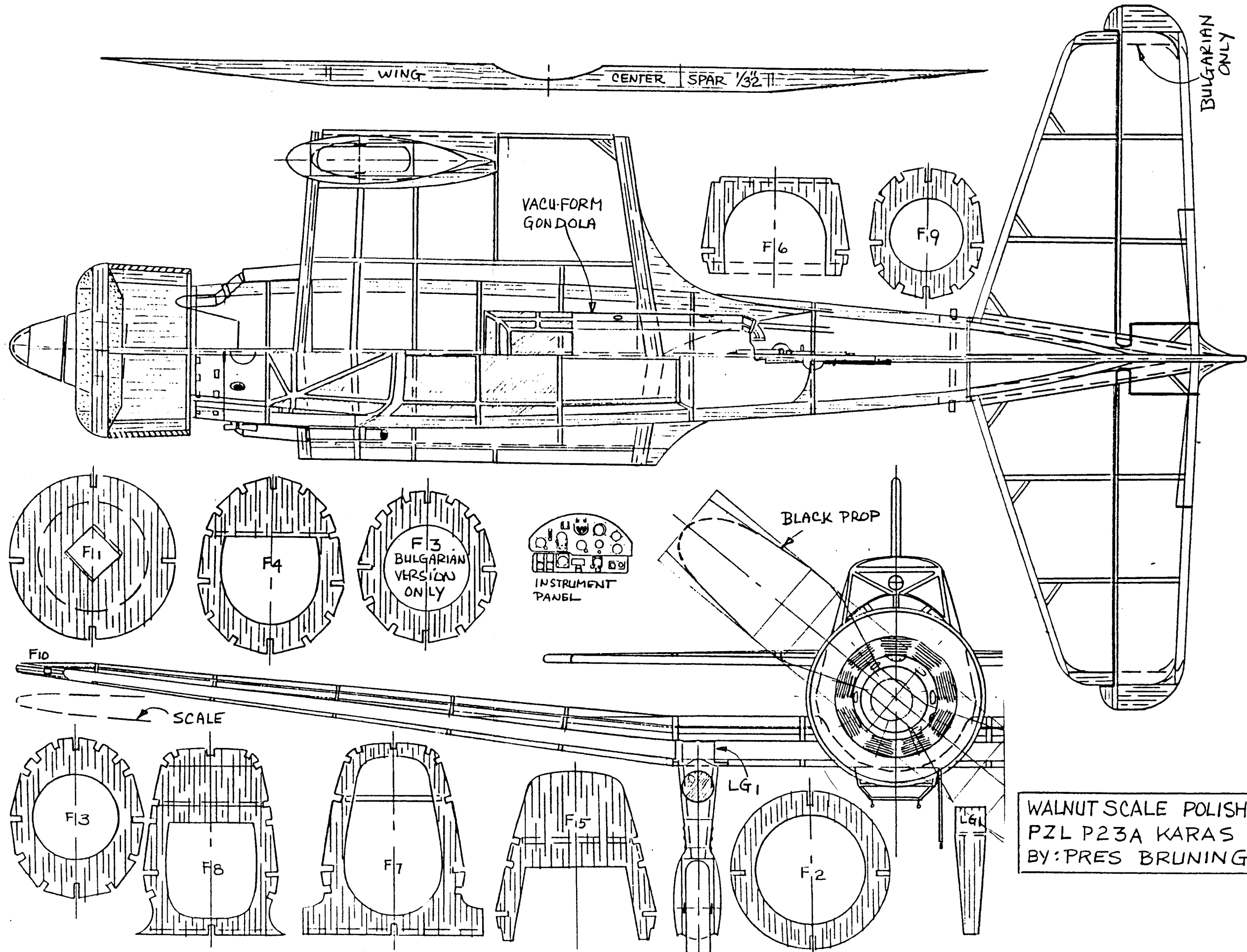

WALNUT SCALE POLISH
PZL P23A KARAS
BY: PRES BRUNING

SQUAD. INSIGNIA: WHITE CROSS
 ORANGE TIGER BLACK STRIPES
 & RED MOUTH

COLOR SCHEME: ENTIRE AIRPLANE
 OLIVE GREEN. LOWER SURFACES:
 OF WINGS, TAILPLANE &
 VENTRAL GONDOLA: LIGHT
 BLUE GREY

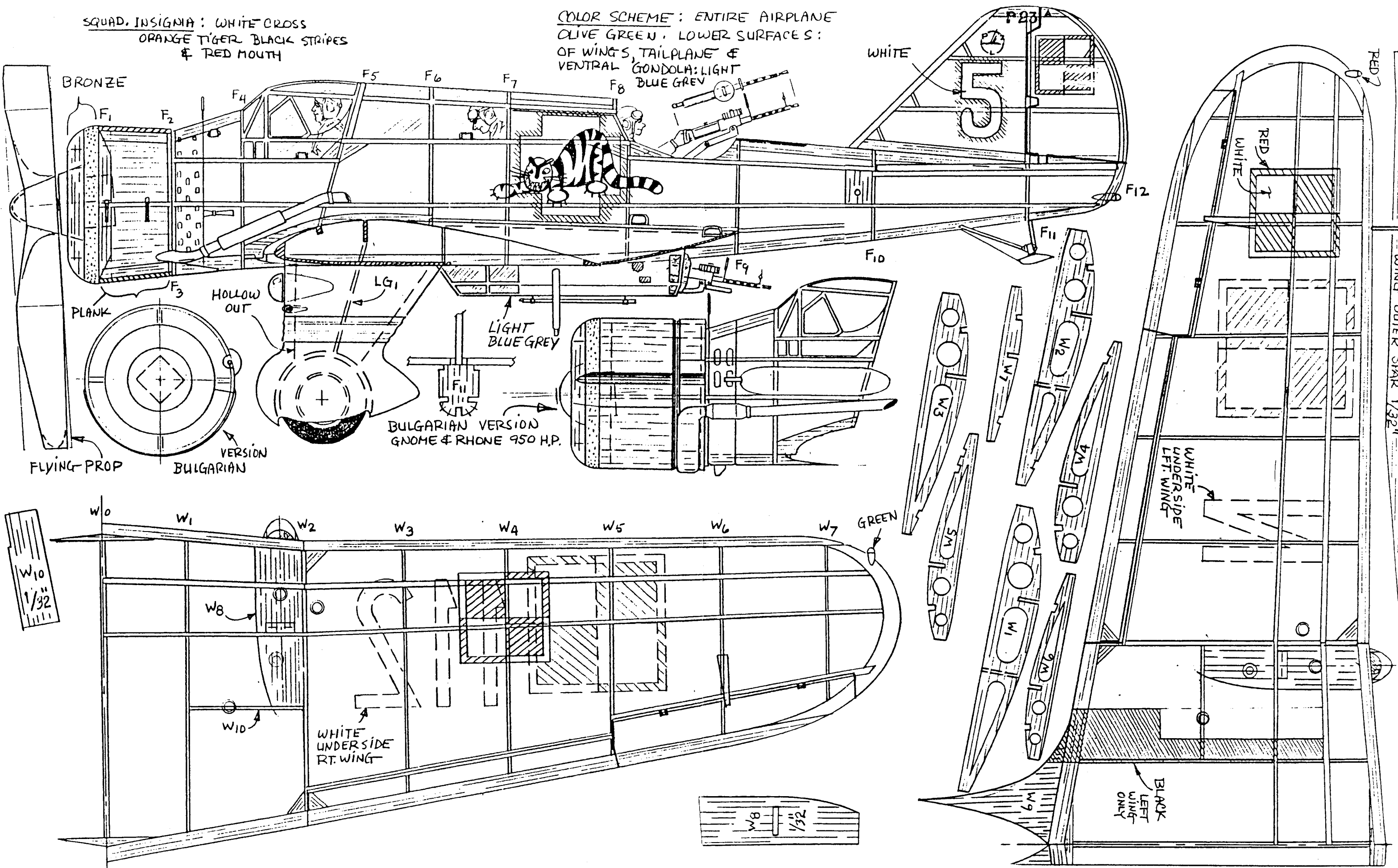

BRONZE

WHITE

F1

F2

F4

F5

F6

F7

F8

F12

F10

F9

F11

PLANK

HOLLOW OUT

LIGHT BLUE GREY

BULGARIAN VERSION
 Gnome & Rhone 950 H.P.

FLYING PROP

VERSION
 BULGARIAN

GREEN

WHITE
 UNDERSIDE
 LEFT WING

WHITE
 UNDERSIDE
 RT. WING

BLACK
 LEFT
 WING
 ONLY

WING OUTER SPAR 1/32"

W10
 1/32"

W8
 1/32"

W9

W7

W6

W5

W4

W3

W2

W1

W0

W3

W4

W5

W6

W7

W8

W9

W10

W3

W4

W5

W6

W7

W8

W9

W10

W3

W4

W5

W6

W7

W8

W9

W10

W3

W4

W5

W6

W7

W8

W9

W10

W3

W4

W5

W6

W7

W8

W9

W10

W3

W4

W5

W6

W7

W8

W9

W10

W3

W4

W5

W6

W7

W8

W9

W10

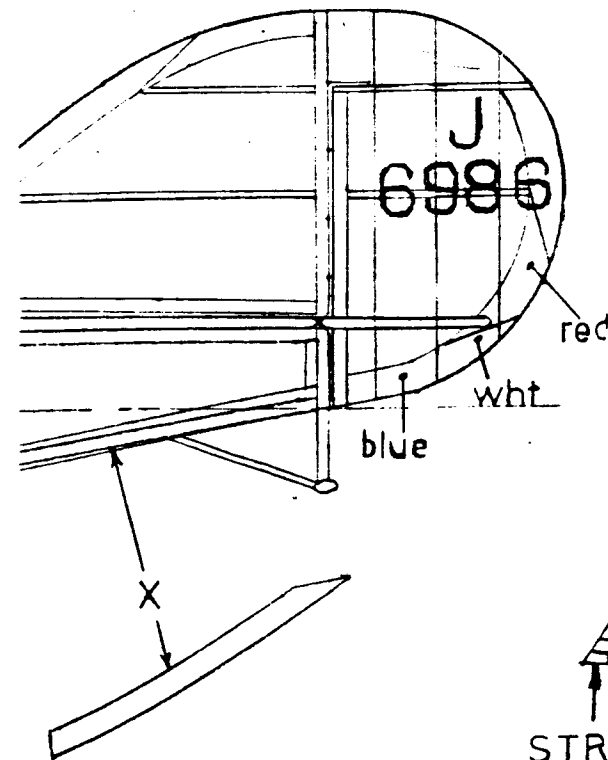
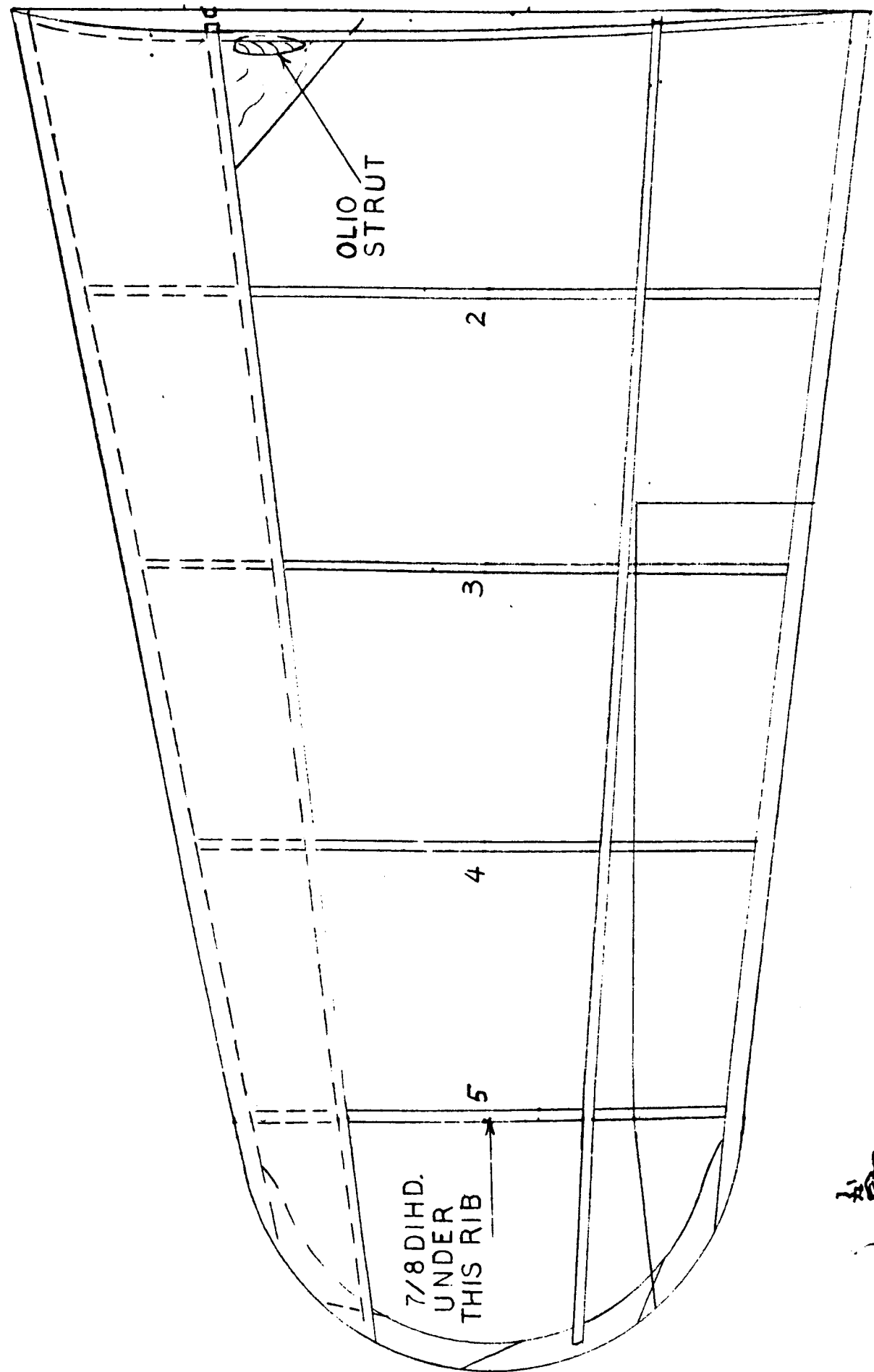

WESTLAND DREADNOUGHT
23 INCH WINGSPREAD

A FLYING club
ACES plan

D.A.S.
10-72

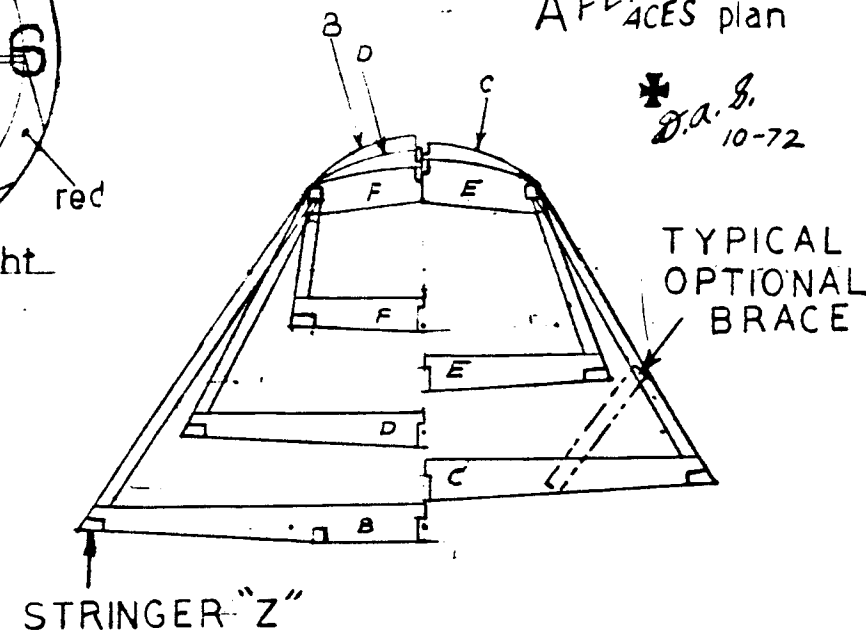

THE WESTLAND DREADNOUGHT

There have been flying wings built a-plenty, we all know, but this is one of the few flying wing fillets we have ever laid our goggled eyes on outside of the Koolhoven FK-55. We are talking about the ship depicted below, Wingsters. The Westland Dreadnought. British you say? Built in England, yes, but her designer was Russian! M. Woyevodsky was his name and his plane was as odsky as his name! Hawww. She crashed on her maiden flight! Anyone courageous enough to give her a test of your own? Throw the rotten tomatoes at Air-Marshal Dave Stott, designer of the model.

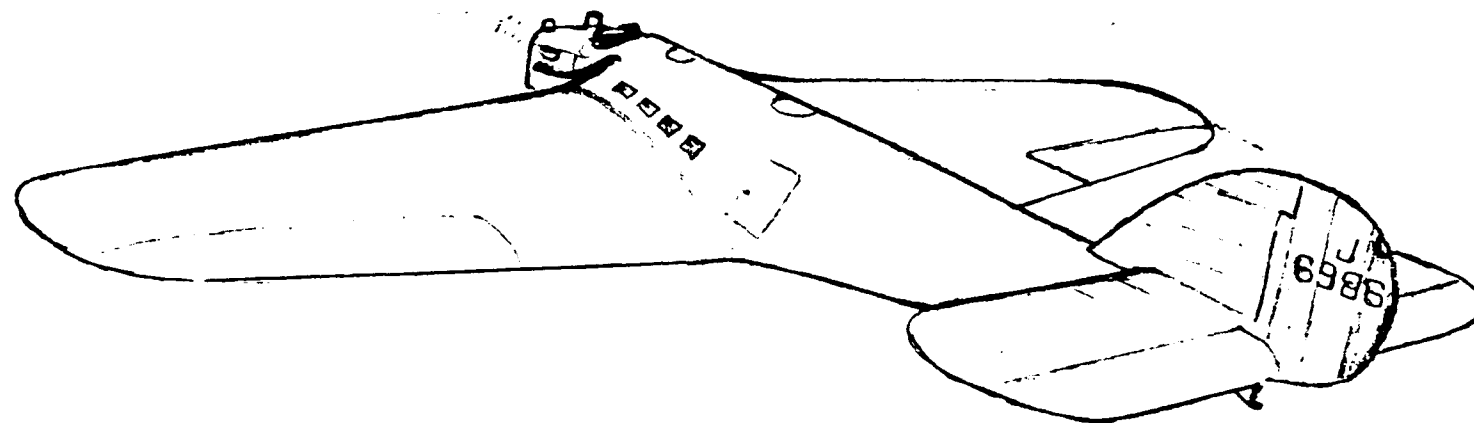
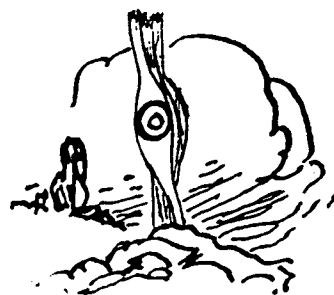

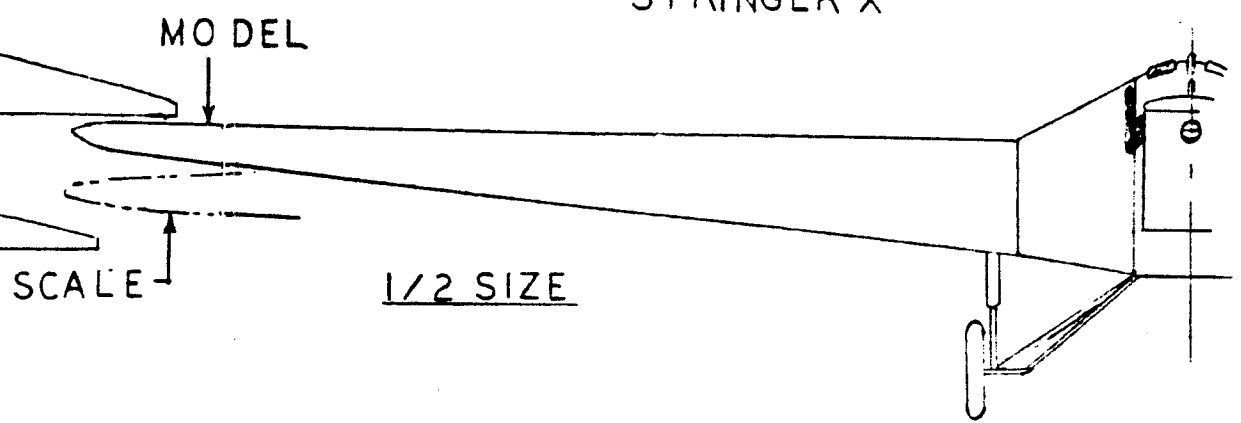
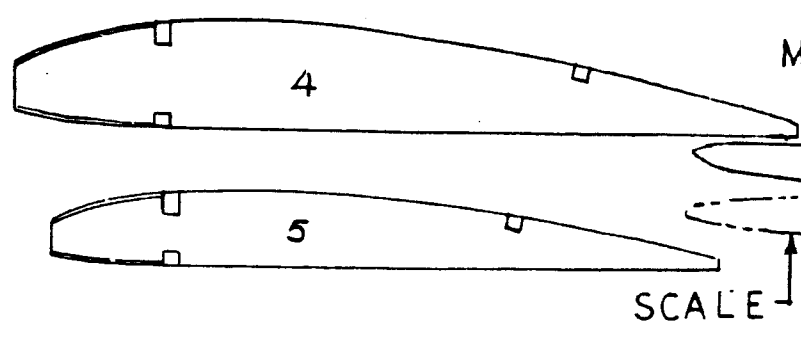
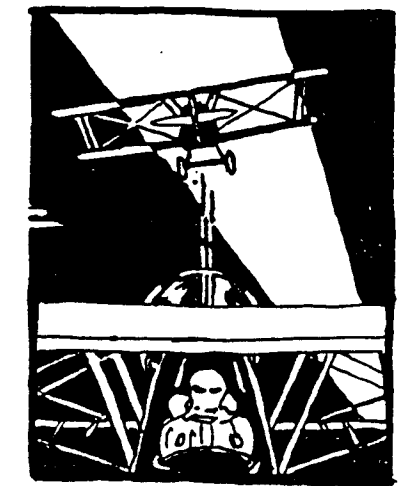
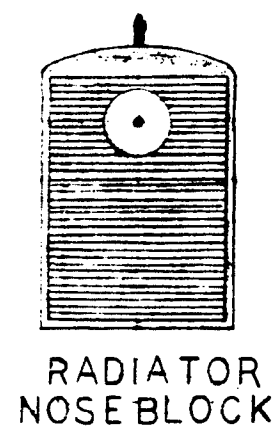
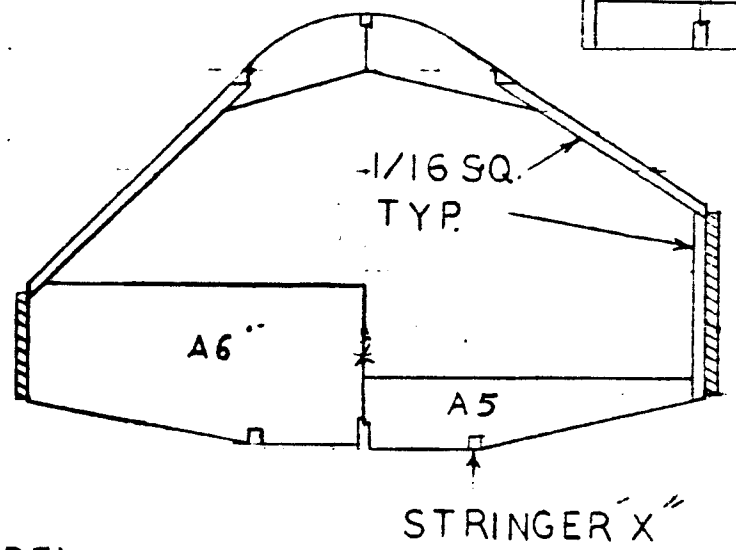
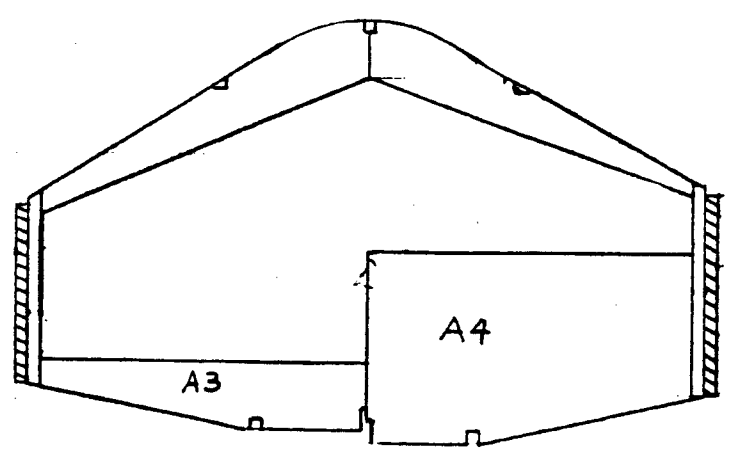
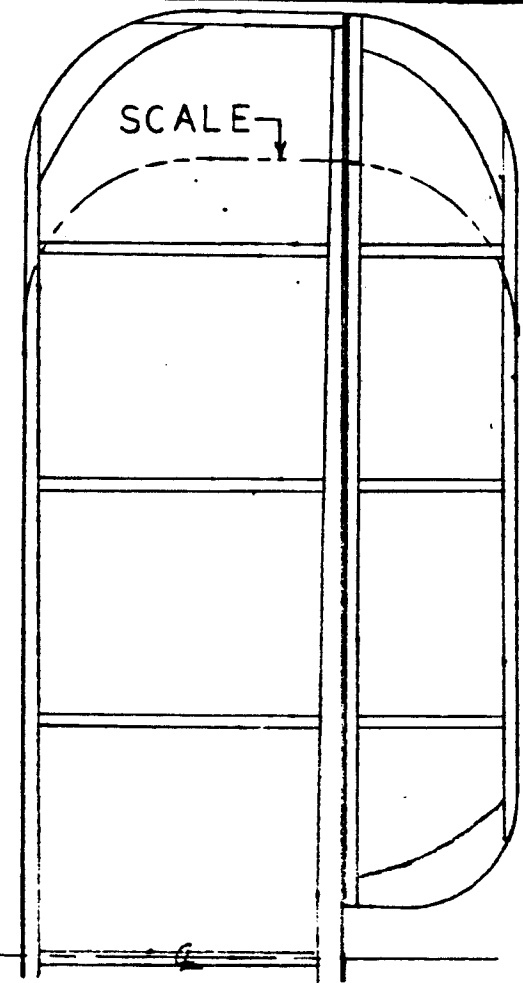
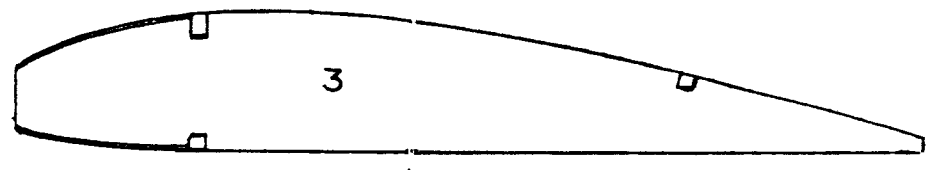
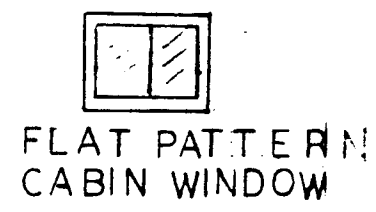
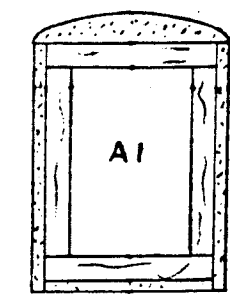
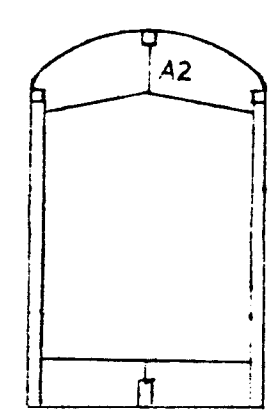
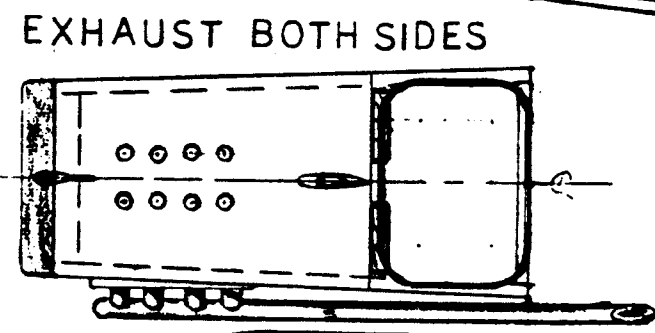
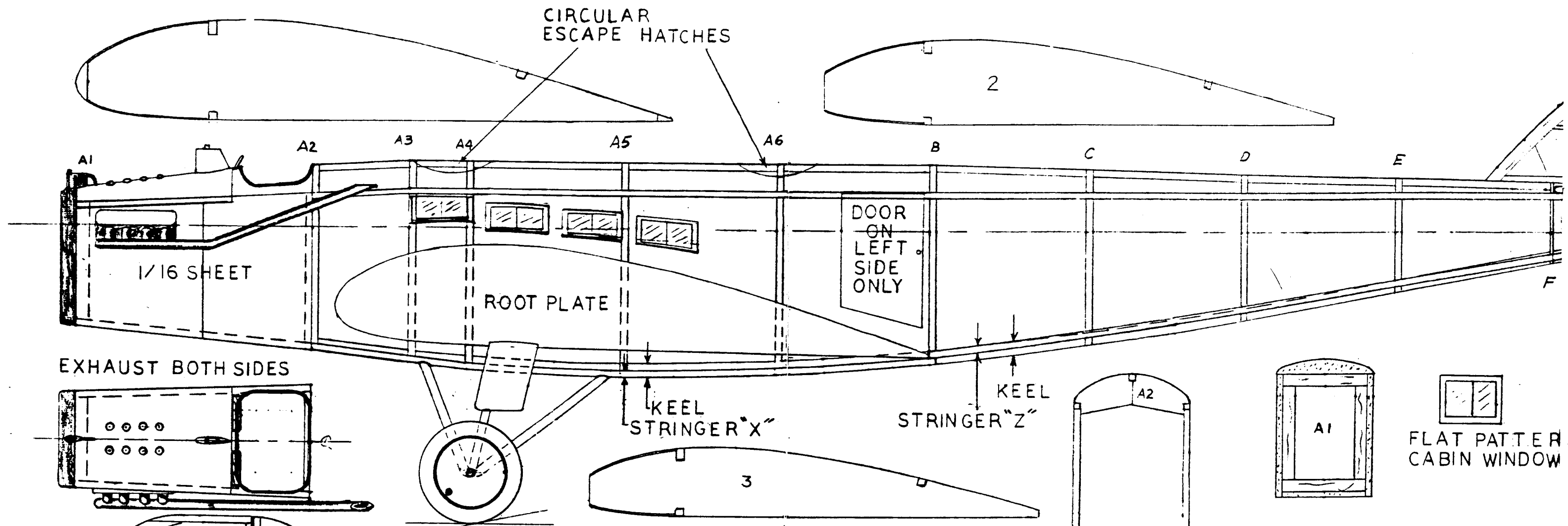

COLOR:
 OVERALL SILVER
 TAIL STRIPES, NO ROUNDED
 BLACK RADIATOR &
 SERIAL NO