

FLYING ACES

Club

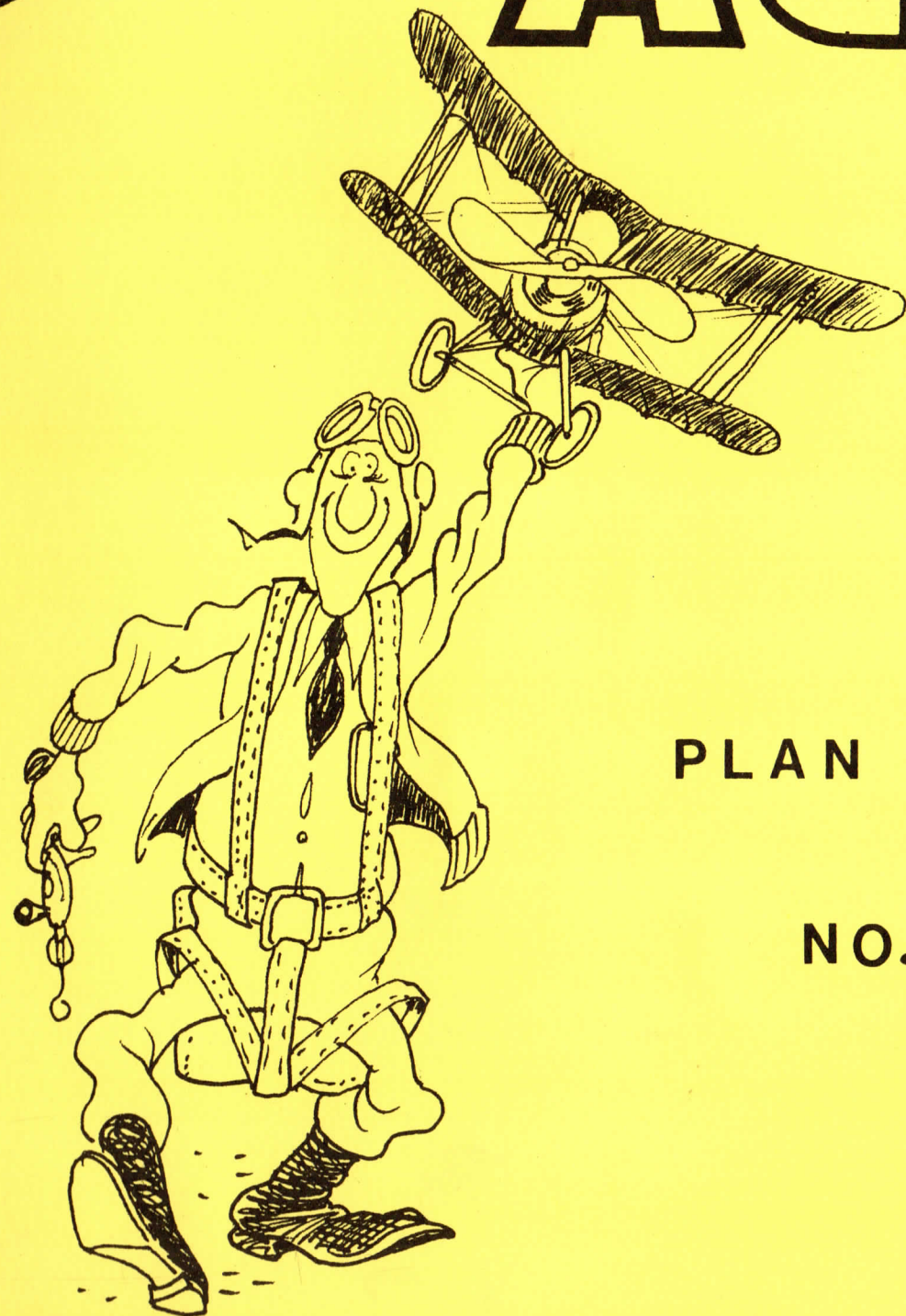

PLAN PACKET

NO. 2



FLYING ACES

3301 Cindy Lane
Erie, PA 16506

Dear Fellow FACers,

Here is your FAC Plan Packet #2. We hope that you like it as well as you did Plan Pack #1. Remember, some of these plans were drawn several years ago and modeling has changed rather drastically since then.

Thrust adjustments, rear peg locations, etc., are now left up to the modeler himself, who has his own system for these things. Set them up in the way that works best for you.

There are eleven plans in this packet, sixteen sheets (11 X 17) with nothing printed on the back so that you can build from them right out of the packet.

We sure would like to see some of these models in the air in 1993. If you build some of these models send us a photo or two and we will print them in the newsletter.

Now, on to the workshop and.....

BUILD--FLY--WIN....EFF--AAA--CEEE!!!!

Table of contents;

1. A.N.T. 14 "Pravda" by Dave Stott 27" span.
2. Boeing P-12E by Bill Miller 12½" span.
3. Ionosphere Intruder Embryo by Dave Stott 22" span.
4. Dornier "Falcke" No-Cal by Dave Stott 15" span.
5. PZL P-46 "Sum" by Pres Bruning 13" span.
6. Fairchild 24 by Hank O'Dwyer 12" span.
7. Martinsyde "Elephant" by Dave Stott 24" span.
8. The "Texan" by Tom Nallen, Jr. 13" span.
9. Vought OS2U-2 "Kingfisher" by Pres Bruning 12" span.
10. Rohrbach Roland by Dave Stott 27" span.
11. Vought SB2U-1 "Vindicator" by Pres Bruning.

This plan packet #2 is dedicated to our dear friend and fellow modeler Emerson Elwell and to all of the other modelers who have gone on ahead of us.

THE A.N.T.- 14 "PRAVDA"

"Hey, Tovarich! You know what mins it "Pravda"? You dun't? I, Ivan Ignace Igor Idiotsky vill told you. It mins troot, like de snow before you eyes in Siberia is pure white---troot, like Lenin toldit us! You dun't tink so, hah? Vot hack you capitalist slaves know anyway. Bah!"

Boy, get that guy out of here, fellas! How did he get into the FAC Model Lab? Cripes, just because we are presenting one of the ships of the Russian "Maxim Gorkii" Squadron this nut breaks in and upsets things. Put a 'chute on him and drop him off over Berkeley California (not the kit makers) as a food gift!

Let's get back down to cruising speed again, Clubsters, and take a look at the history of this big sky goliath. The "Maxim Gorkii" Squadron was formed by Commie big shots to impress the peasantry with the progress of the Mother Country under Uncle Joe Stalin's leadership. The flagship of the squadron was the six (and then eight) engined Maxim Gorkii ship itself. The world's largest land plane at the time. There were other large airplanes in the squadron. The A.N. Tupolev -14 was one of these machines. Except for the Maxim Gorkii itself, all ships were named after Red newspapers. The A.N.T.-14 was dubbed Pravda.

The function of this squadron was to visit collective farms that had a top production record (and could provide a good landing field, which no doubt took up enough acreage to kill chances of being in the top ten next year). As the ship approached loudspeakers on board would announce the arrival with music and patriotic speeches. The ship would land amid cheers and gifts would be exchanged as the crew set up a movie camera and screen to show what progress was being made by the great new government! Oh well fellas, I guess if you had one loasy chicken all your life and somebody gives you another it makes you happy! So much for history. Now on to the model....

Air Marshal Dave Stott is the designer of this crate and has had her slicing ozone for quite some years now. A rarity in that it is one of the few five engined planes in the world and yet has many good features to make its chances of being a good flyer as numerous as ants at a picnic. Construction is pretty standard. Wood sizes can be scaled from the plan. Landing gear struts were made of bass wood and the wheels were vac-u-formed of clear plastic leaving the centers clear as the real ship had uncovered spoke wheels! (More progress under Uncle Joe!)

Engine nacelles are rolled of 1/64 sheet balsa with turned cowls. Some photos of the real ship show cowl bumps, some smooth, some with holes where the bumps used to be and still others with no cowls at all! Some shots also show the ship on skis, so take your pick of configurations. All are correct.

The flight engineer's cupola was vac-u-formed over a balsa block form as was the pilot's cabin. Dummy props were carved from mahogany and were typical World War I in style! (Still more progress under great Stalin) A flying prop was used carved from a block 1 X 1 1/2 X 8 in the usual Earl Stahl form. Power on Dave's model was six strands of 1/8 Pirelli, which is a nasty thing to call out for a power plant these days!

Now for the coloring and marking that can get you a good share of scale points at the next FAC Contest, Prop Twirlers! A look at the pics show the area above the top longeron and below the bottom one were black. The nose from section B-B forward was black. The engine cowls and nacelles were also black as was the registration and oblong area surrounding the passenger cabin windows. Landing gear struts and tail wheel were black. The rest of the airplane is silver.

Although an over scale size rudder is shown, the test ship flew as well with either scale or over-scale one installed. Stabilizer is, as is usually the case, over-scale.

"You vant see peautiful sight of Ukranian wheat filds shining lak golt in sunzet? Den by Trotsky, you trotsky down to hobby shop and gat balza voodens and gat bitzy and mak heem yousalf one deez beeg trans-Siberian Sky Sleds, yah!"

Hey! I thought you G-2 men got rid of that gut! Cripes, he reeks of vodka. I bet he is wearin' red flannels. One thing is certain, his orbs will be crimson in the A.M. Boys, we have got to tighten security around here. Next thing you know some of these womans libs will be wanting to steal our crates to hunt for Amelia Earhart!

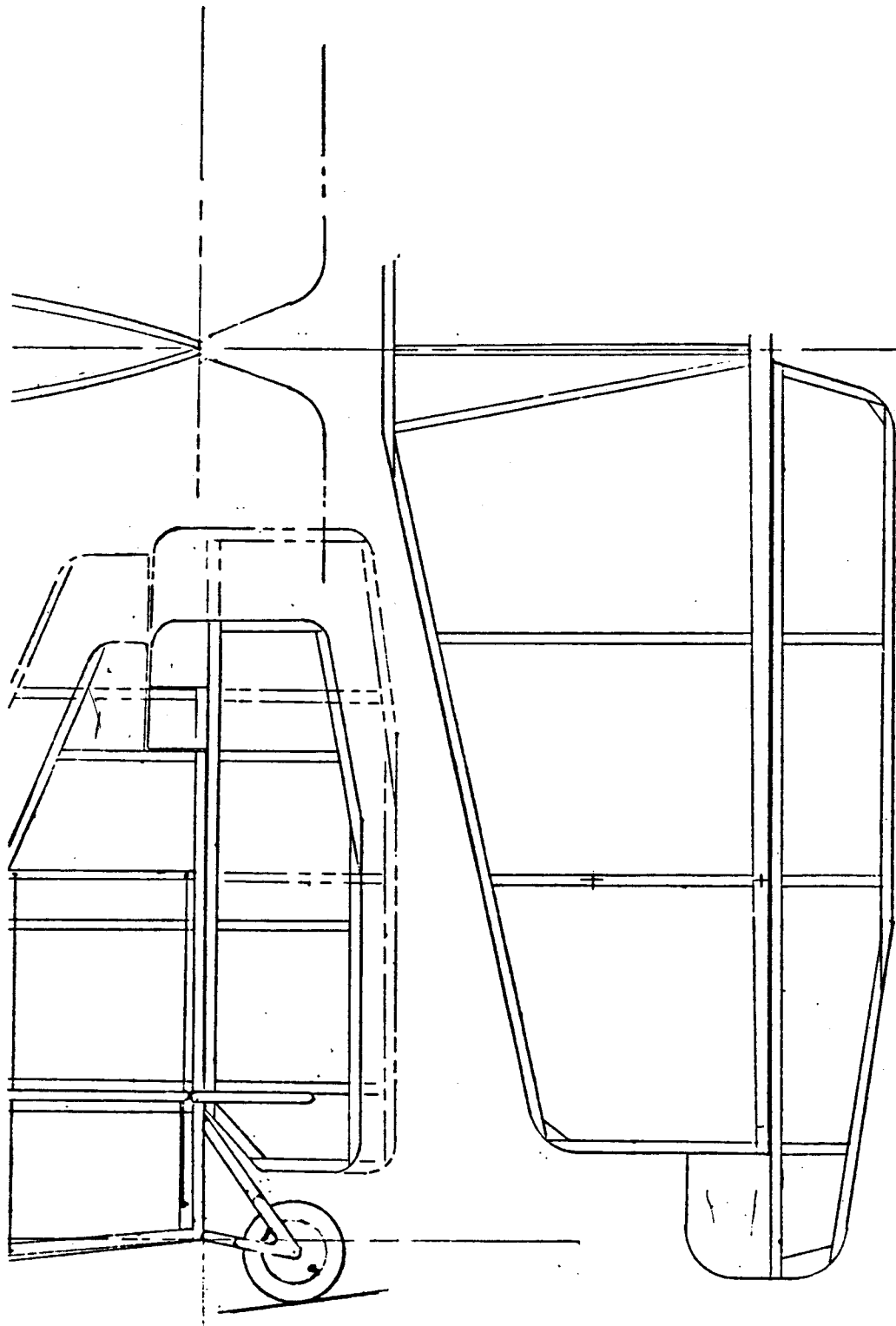

MILLER'S MODERATELY MODIFIED MEGOW MODEL

BOEING P-12E

That master of manipulation is at it again, gang! Yep, Lt. Bill Miller has made just the right subtle changes in the old 10¢ Megow Boeing plan to bring her up to a passable state of "scale". And look how he does it....all in good taste, as well as in the style of the original work. Boy fellas, what a swell crate to do up in the all yellow scheme of the Taipan of the Dragon Squadron, Battlin' Mord Grogan, hero of the China skies long before Chennault got there for Chiang Kai Shek and Democracy. Of course, Mord was only a fictional hero from the pages of the Flying Aces magazine of old. But to a true FACer, he was as alive as one Phineas Pinkham.

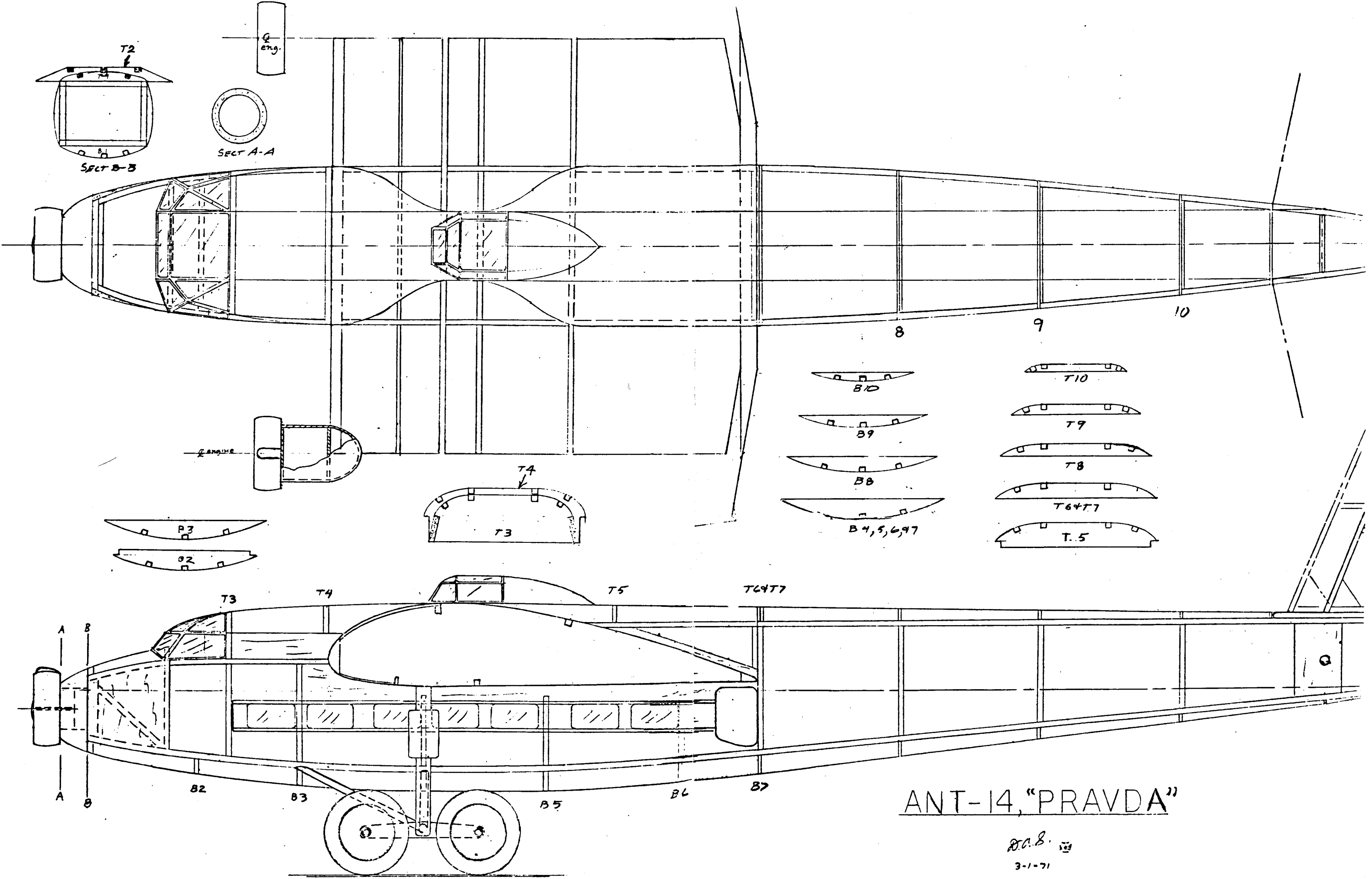

ANT-14, "PRAVDA"

D.A.S. 
 3-1-71

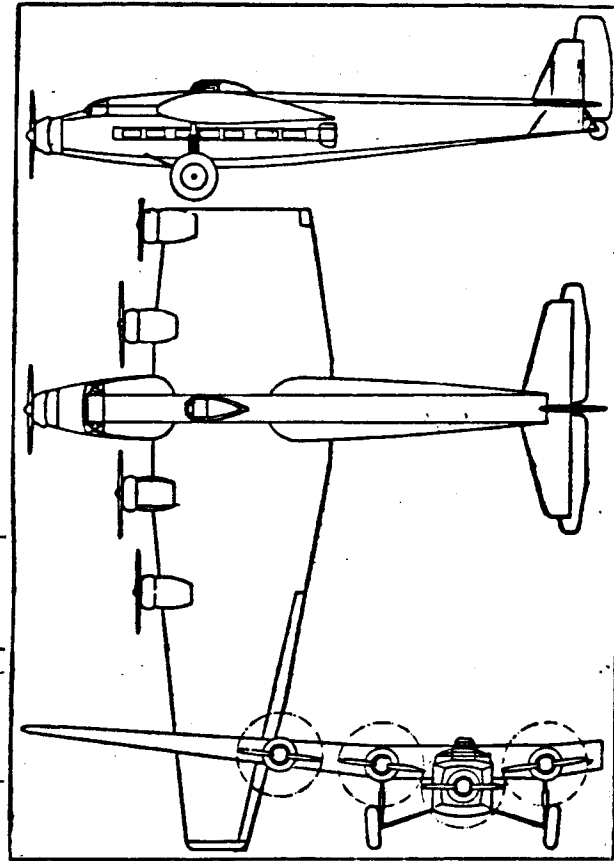
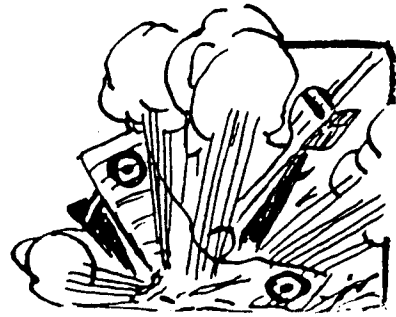

The A.M.T. 14 Five-engined Monoplane.

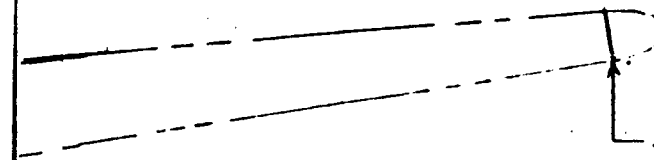
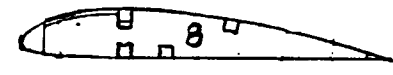
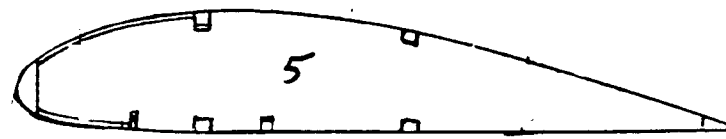
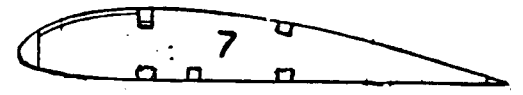
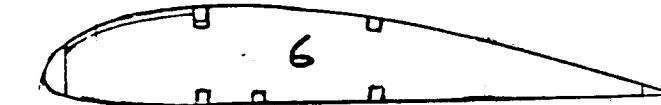

1 1/2 DIHEDRAL

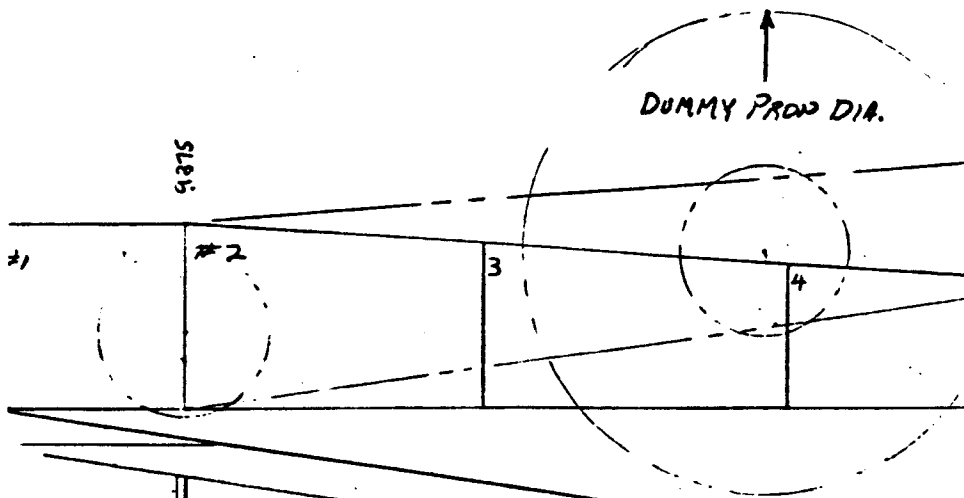

DUMMY PROW DIA.

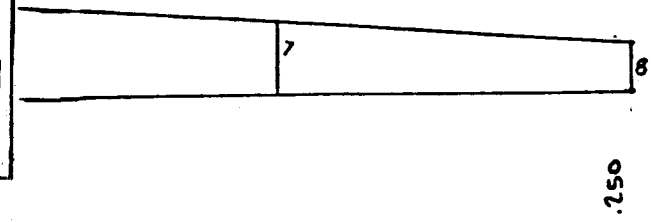

.250

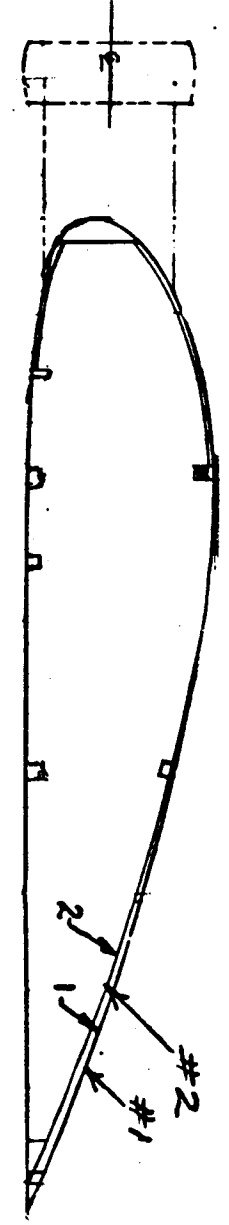
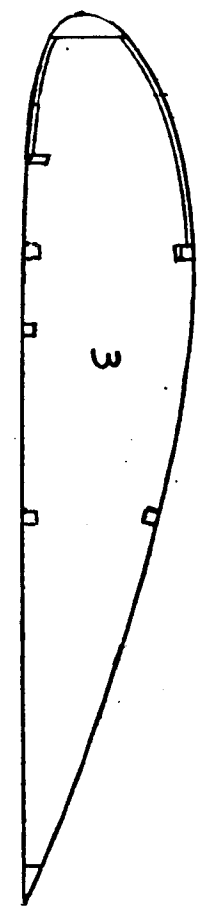
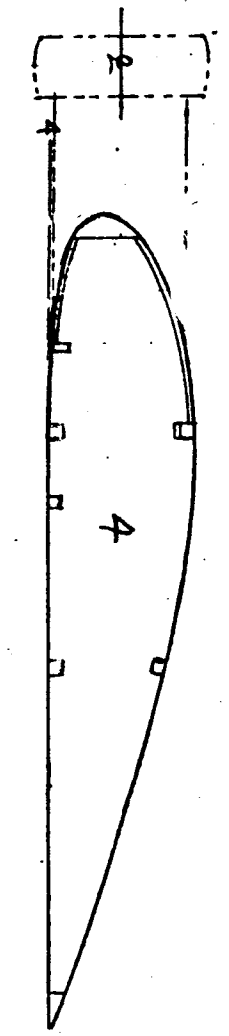
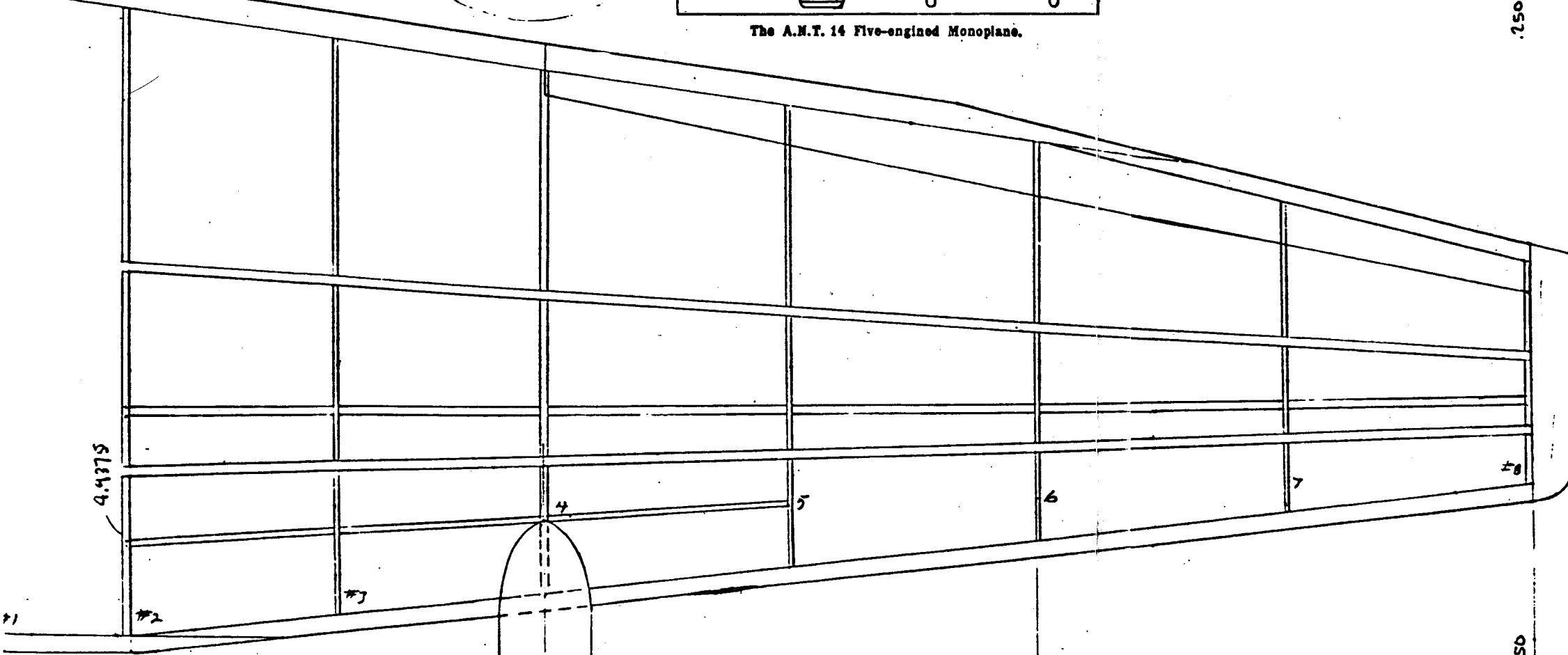

1.8750

3.1875

4.4375

inboard wing

#1

#2

#3

#4

#5

#6

#7

#8

9.375

#1

#2

#3

#4

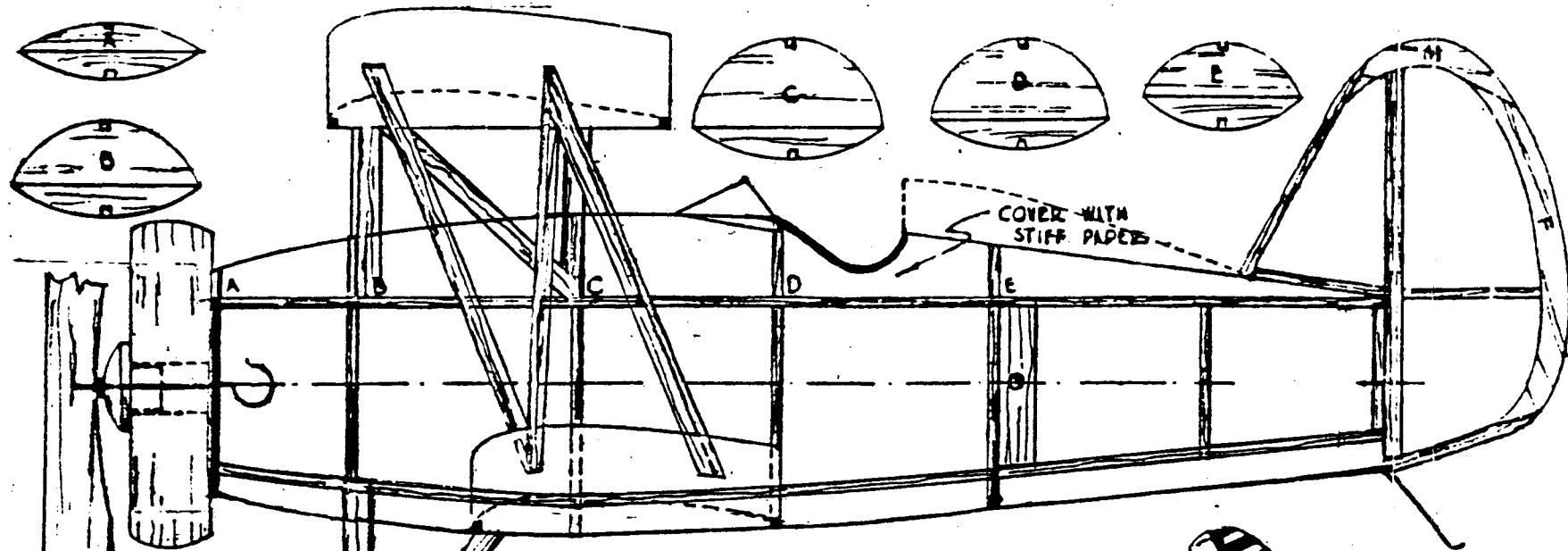

• SIDE VIEW •

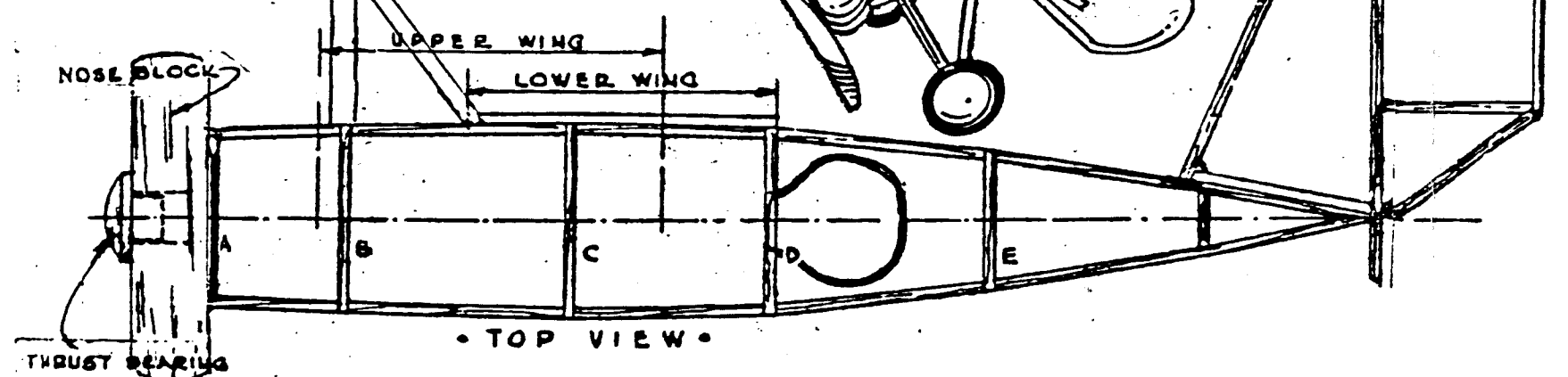
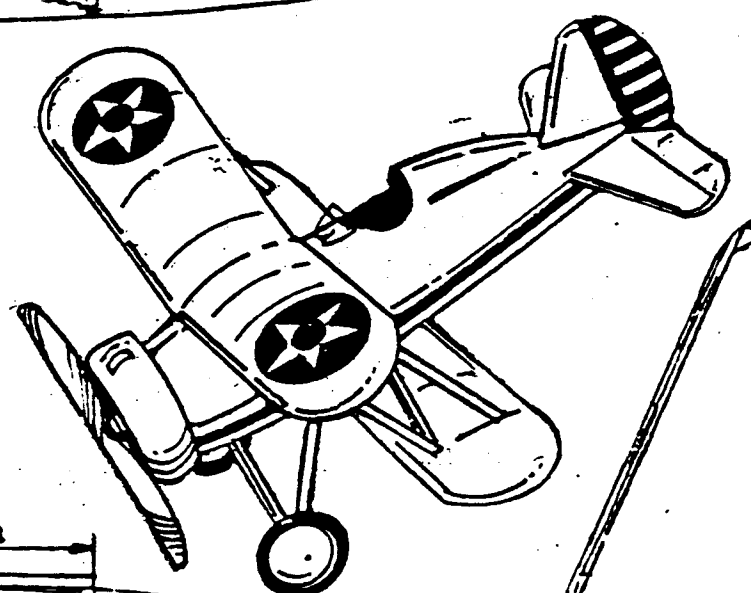

• TOP VIEW •

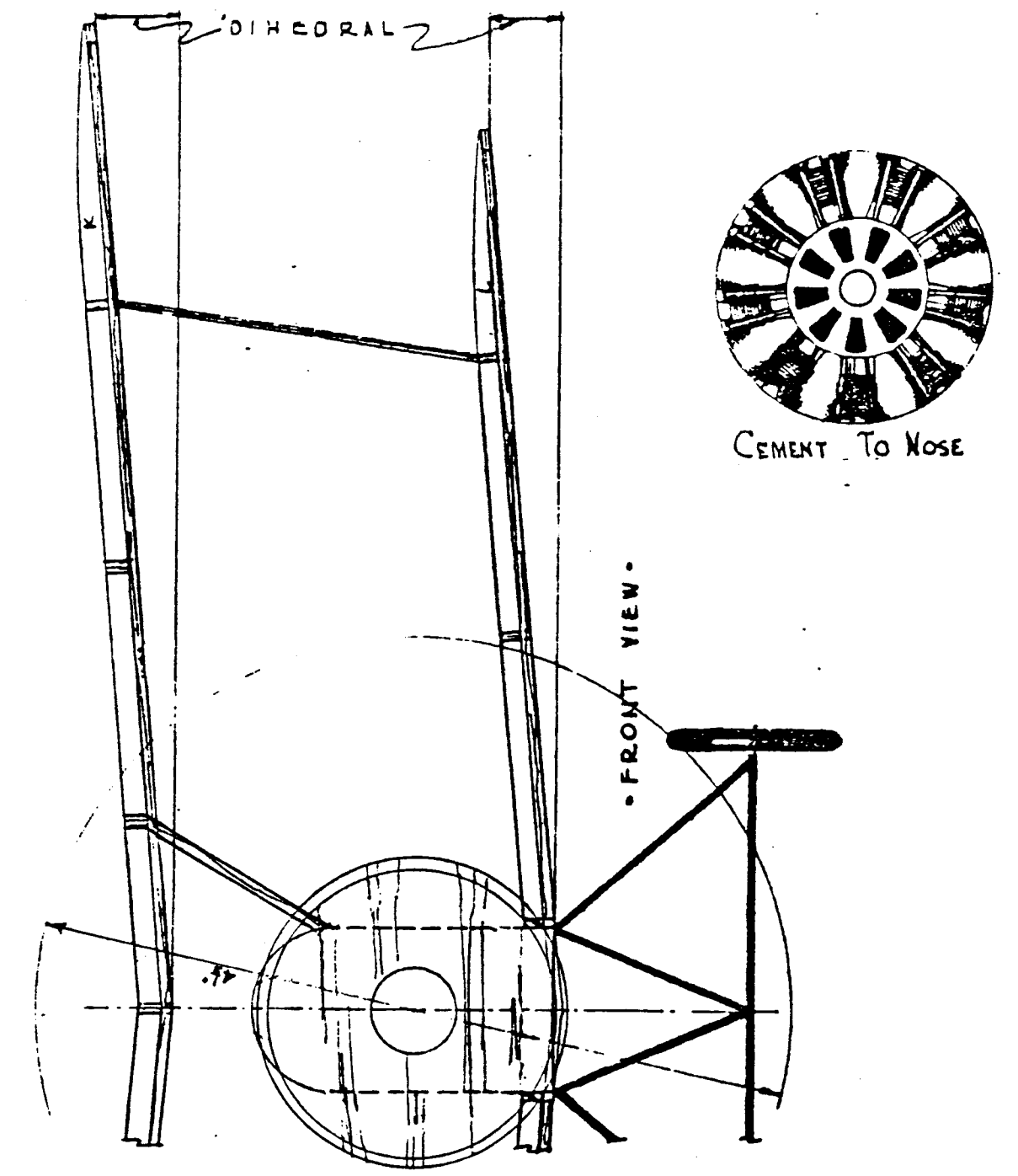

• FRONT VIEW •

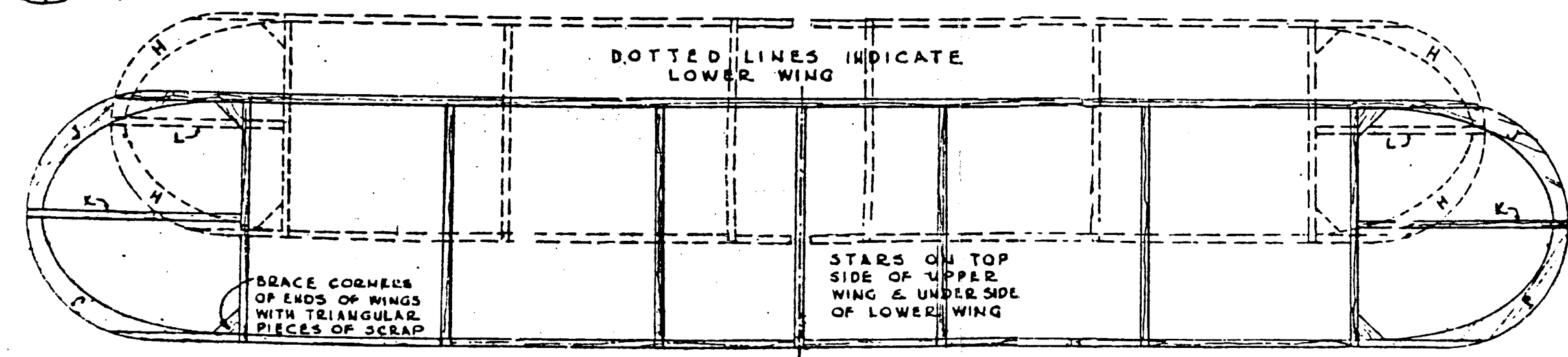

DOTTED LINES INDICATE LOWER WING

BRACE CORNERS OF ENDS OF WINGS WITH TRIANGULAR PIECES OF SCRAP

STARS ON TOP SIDE OF UPPER WING & UNDER SIDE OF LOWER WING

• WING PATTERNS •

MILLER'S
MODERATELY
MODIFIED
MEGOW
BOEING P-12E

If you purchased this plan packet and you are not a member of the "Flying Aces Club" you can join by sending \$9.00 to: FAC, 3301 Cindy Lane, Erie, Pa. 16506.

This will get you on the membership list and entitle you to six issues of the newsletter and all rights and privileges of the "Flying Aces Club".

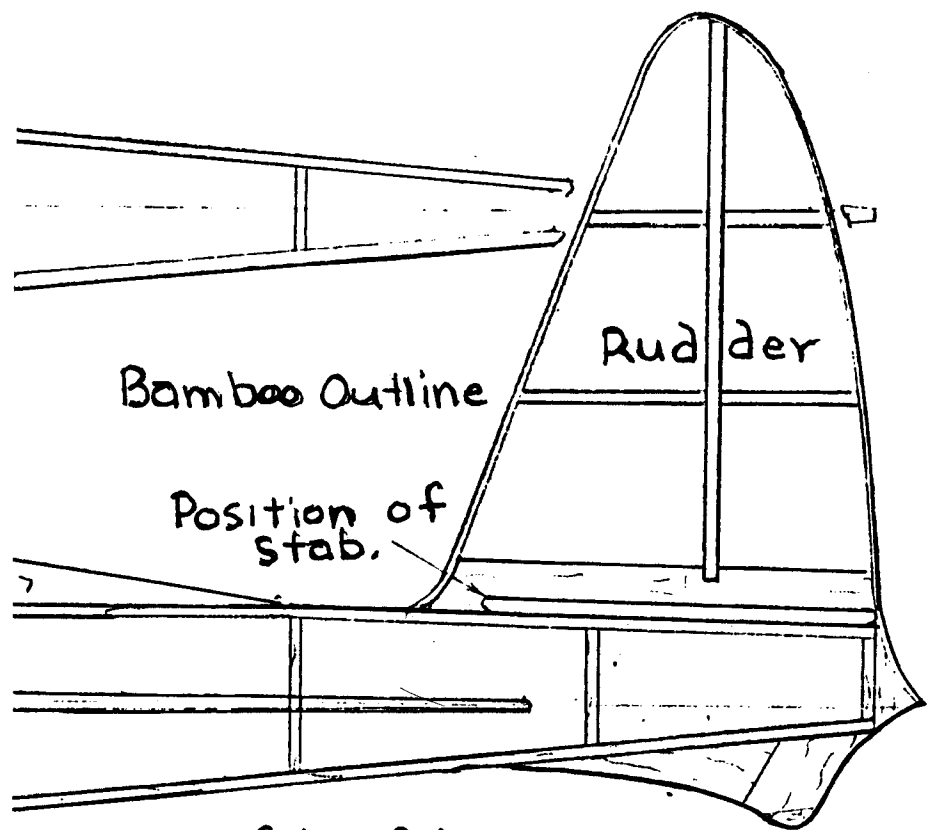

Color Scheme:
All over ethereal white w/contrasting trim.

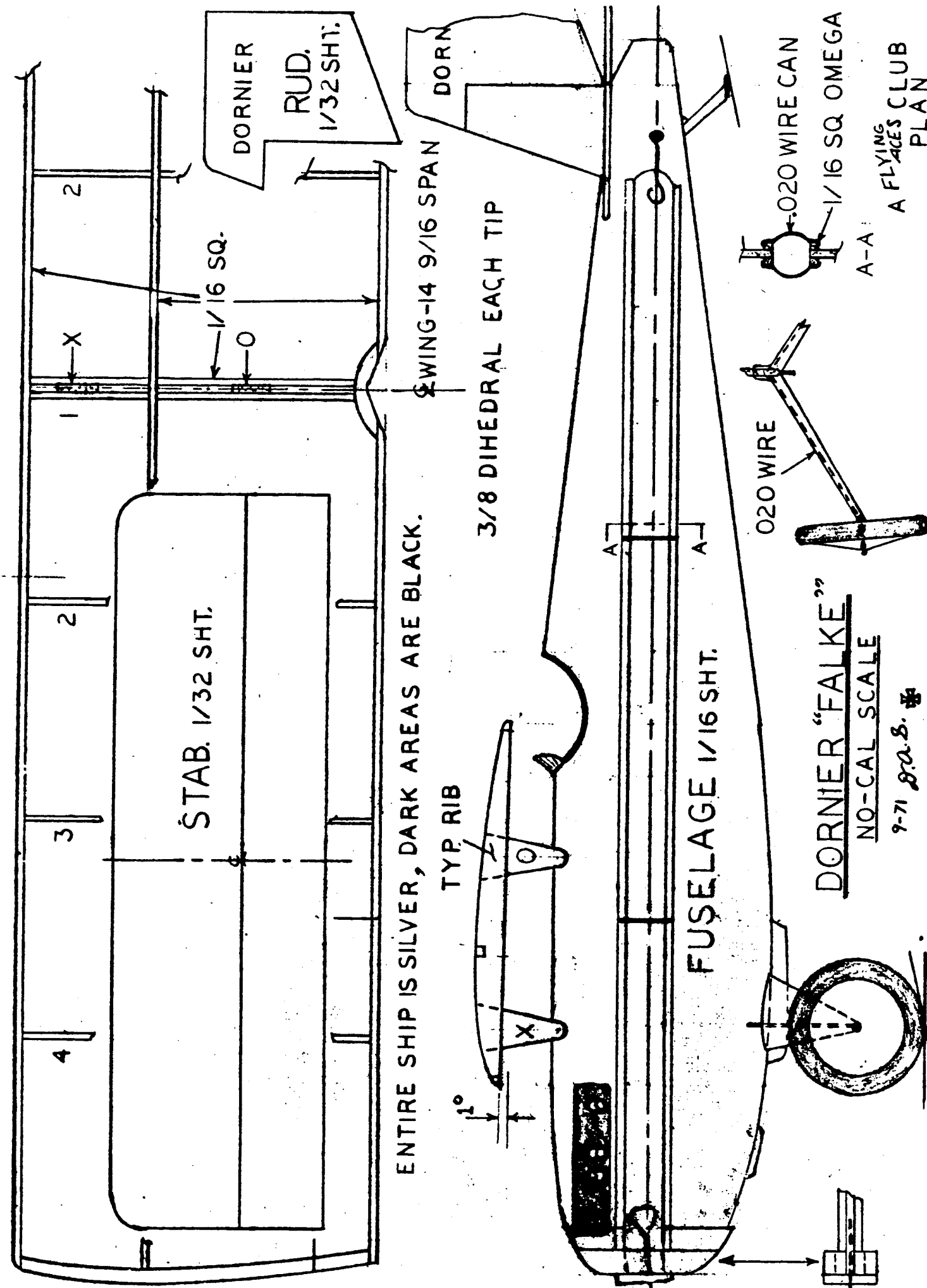
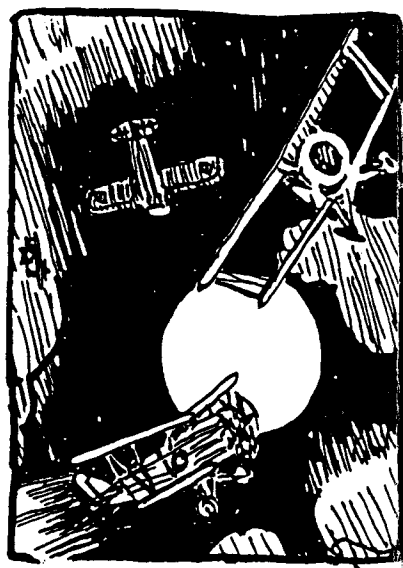
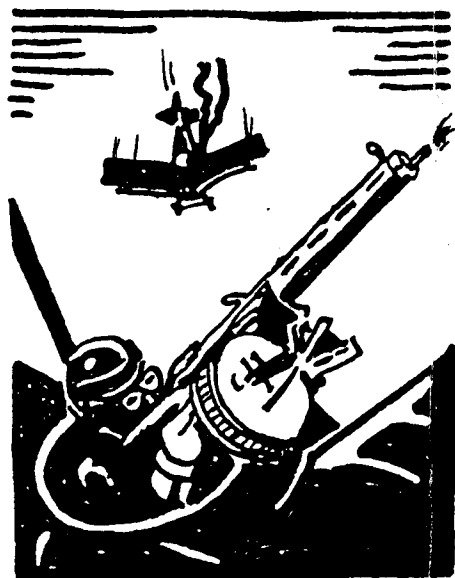
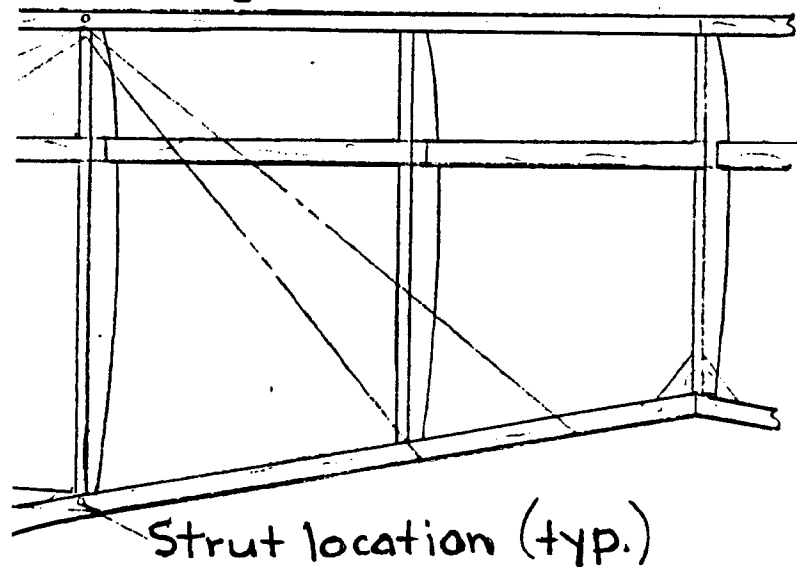

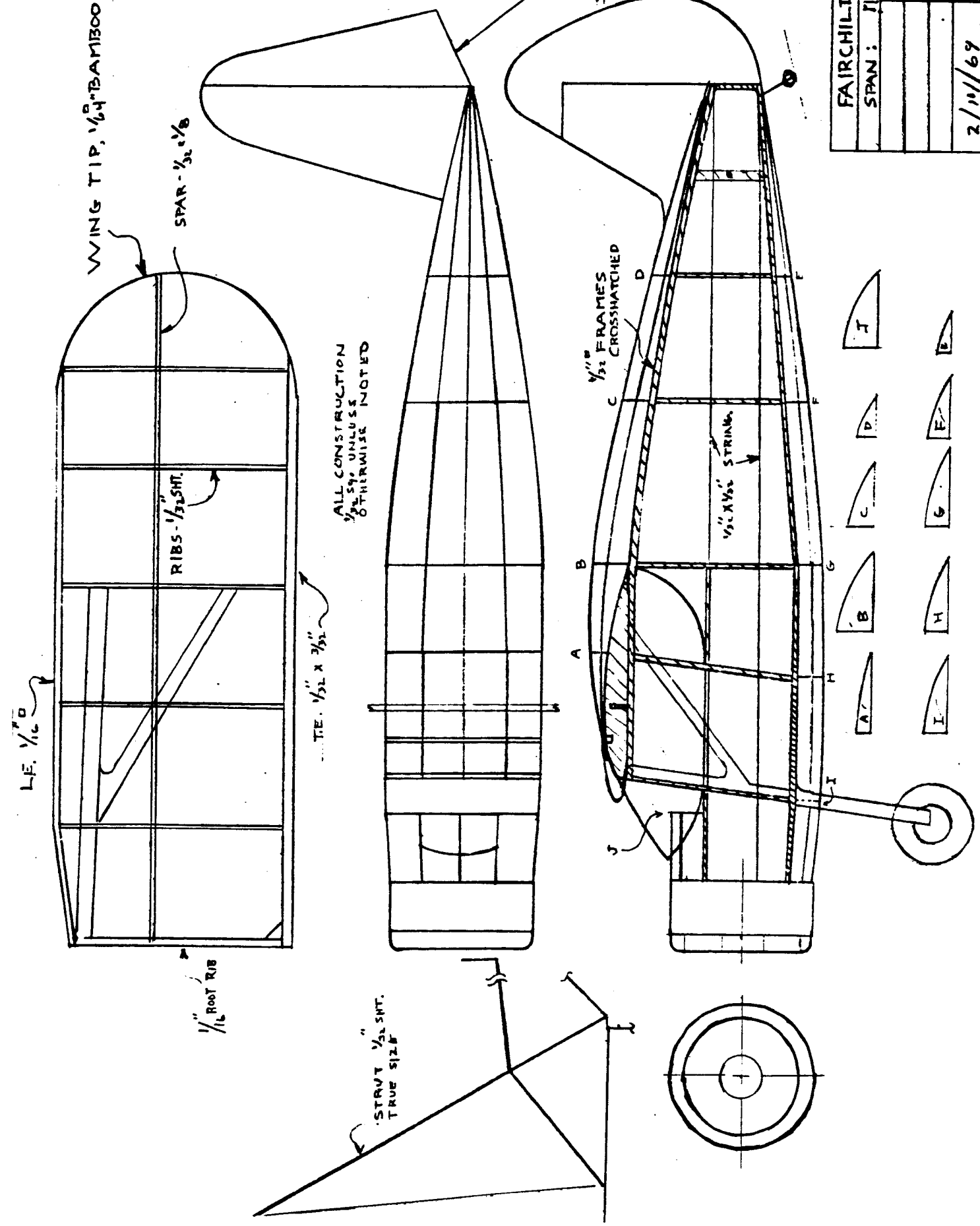
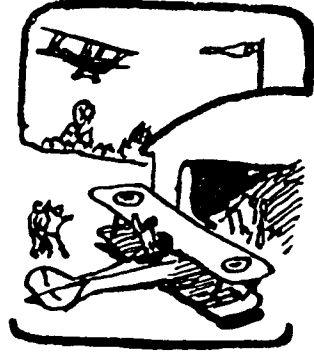
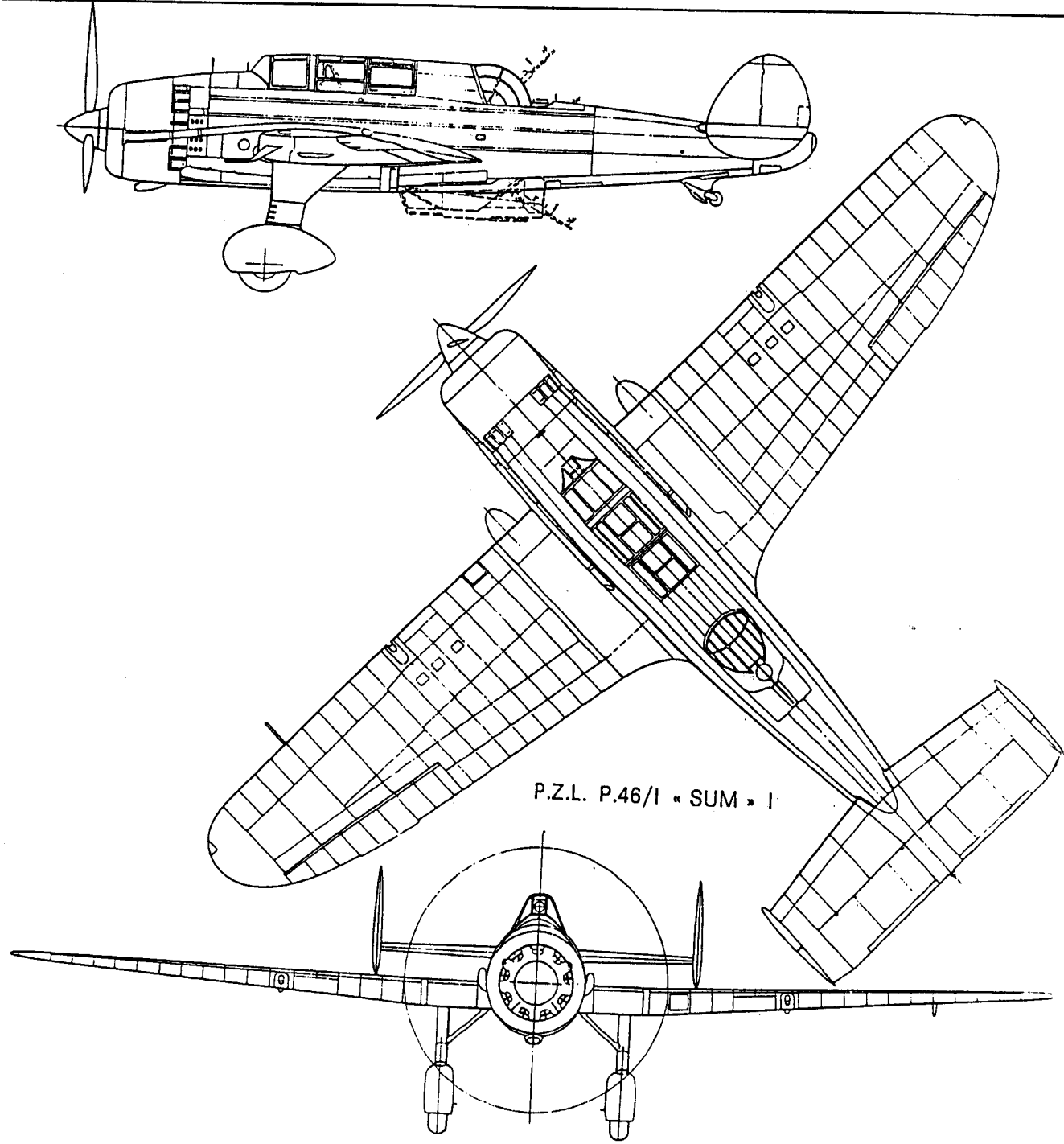

FAIRCHILD 24
SPAN: 11' 3/4"
2/10/69
H.D. Dwyer

THE FLYING ACES IONOSPHERE INTRUDER EMBRYO MODEL

Wingsters, we ask you....what good is an air corps without a research and development outfit to push sky knowledge to the highest limits? So now that you have your Bomber Trainer and Pursuit squadrons all outfitted with real cloud clippin' crates it is time to open your own Wright Field for experimental crates.

Just get a gander at this high altitude design Air-Marshall Dave Stott has whipped off his drawing board. A pressurized cockpit (ala Guerchais 110) keeps our pilot alive in those upper limits, while that exhaust driven supercharger alongside the engine cowl boosts the power to whip that thin air around. And how about those rocket ship-like points on the trailing edges of things there...Great Hung, this job is sure to fly right out of sight on the first sunny day!!!

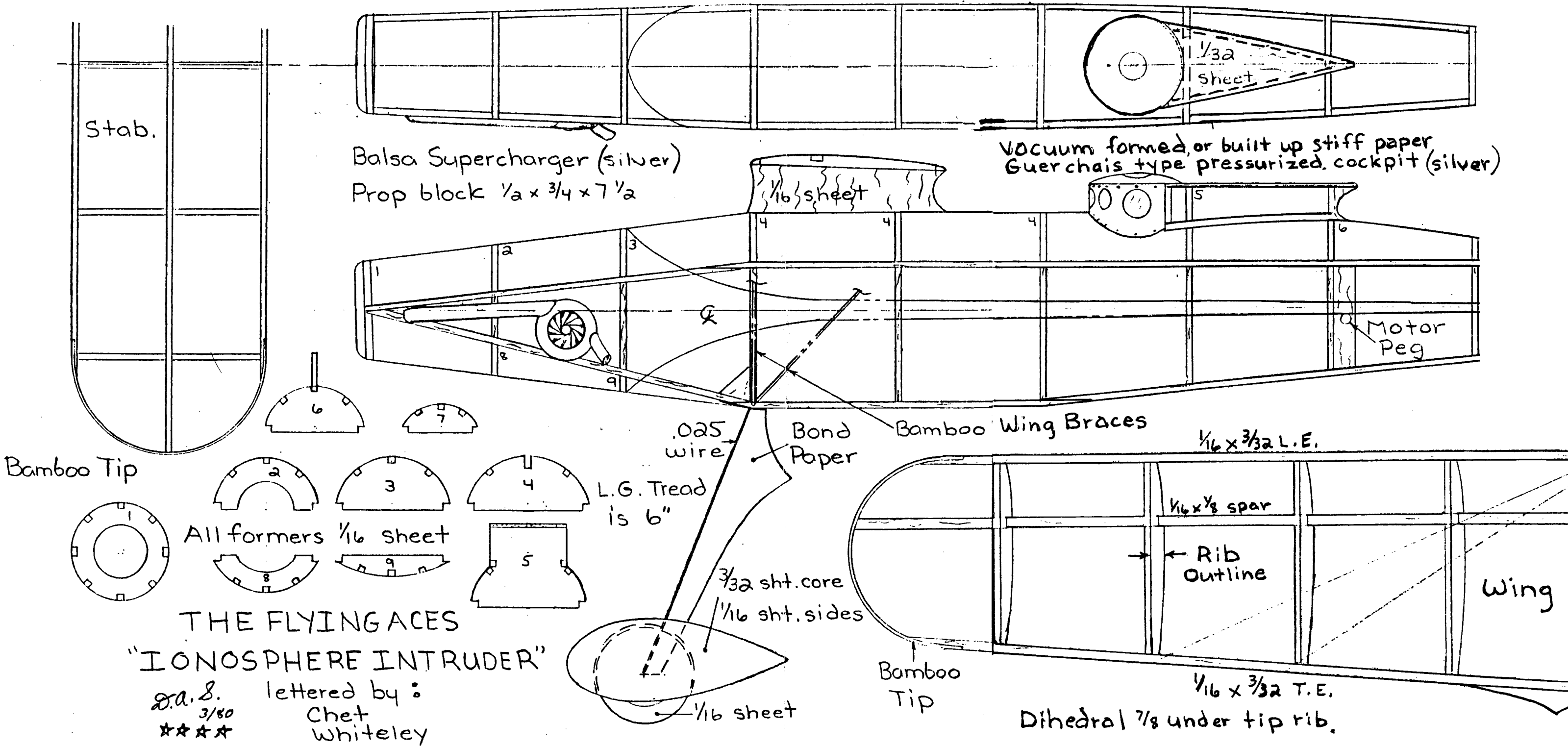

THE FLYING ACES
 "IONOSPHERE INTRUDER"
 d.a.s. 3/60
 ★★☆☆
 lettered by:
 Chet
 Whiteley

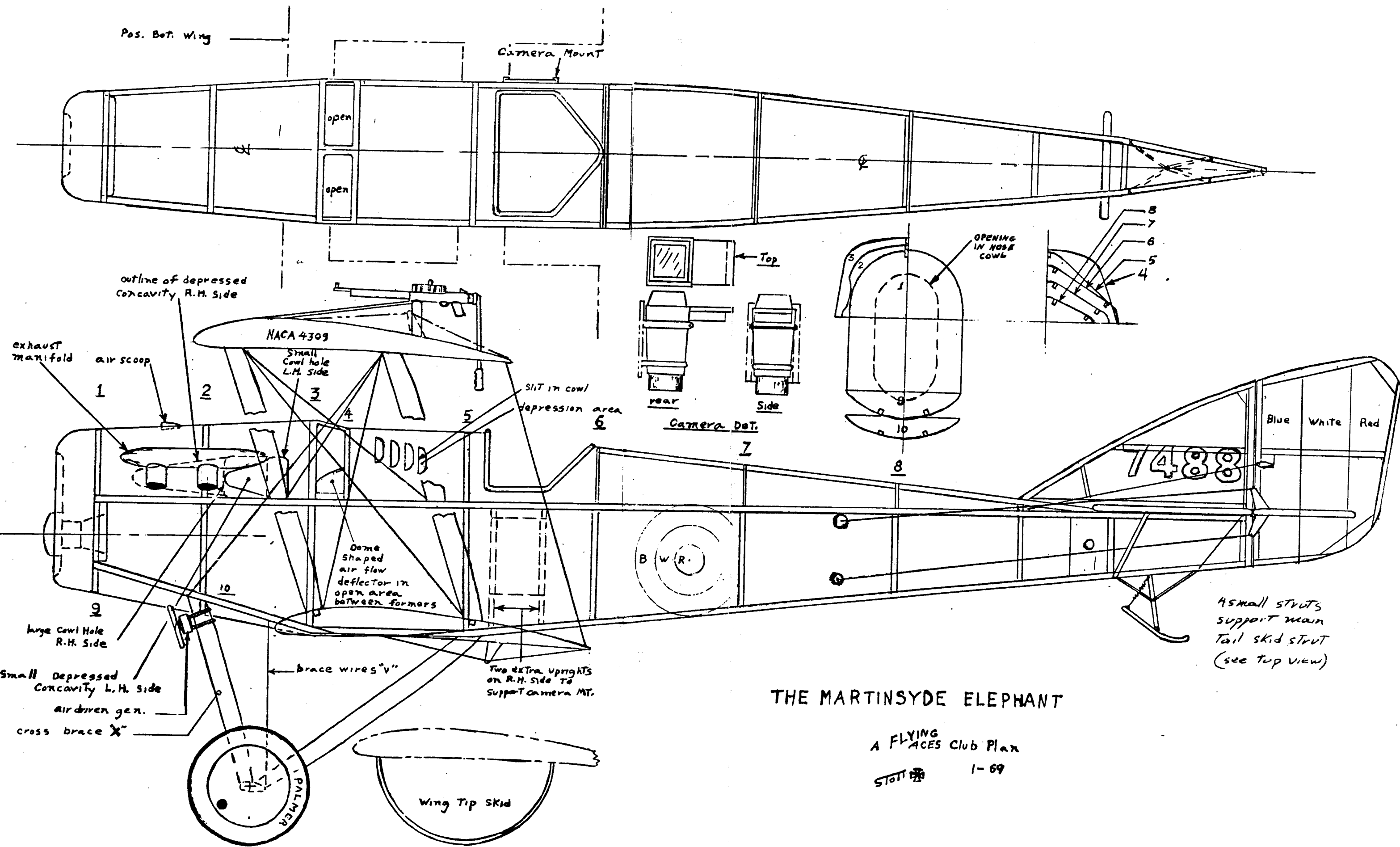

THE MARTINSYDE ELEPHANT

A FLYING ACES Club Plan

STOTT 1-69

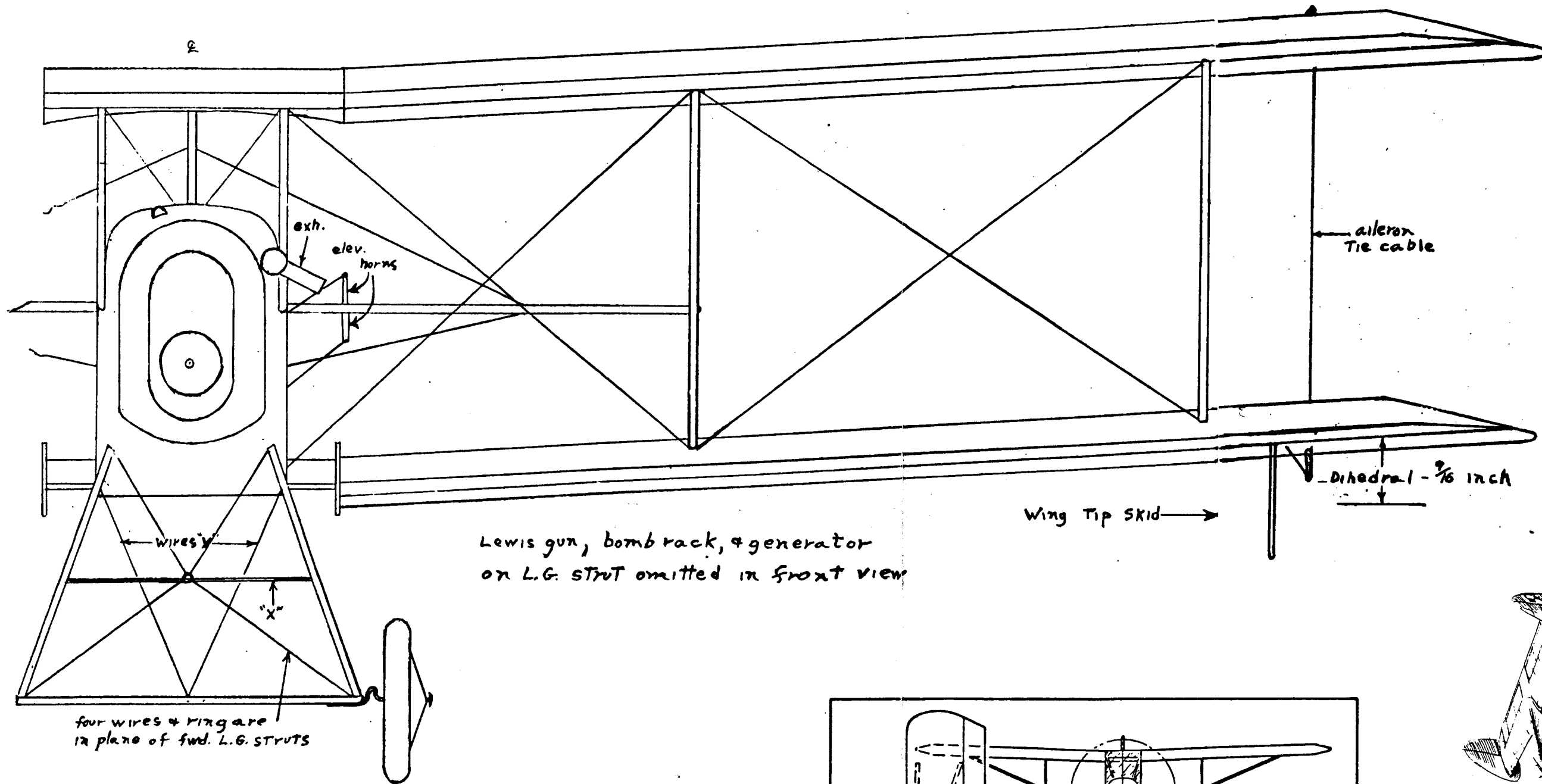

Lewis gun, bomb rack, & generator on L.G. STRUT omitted in front view

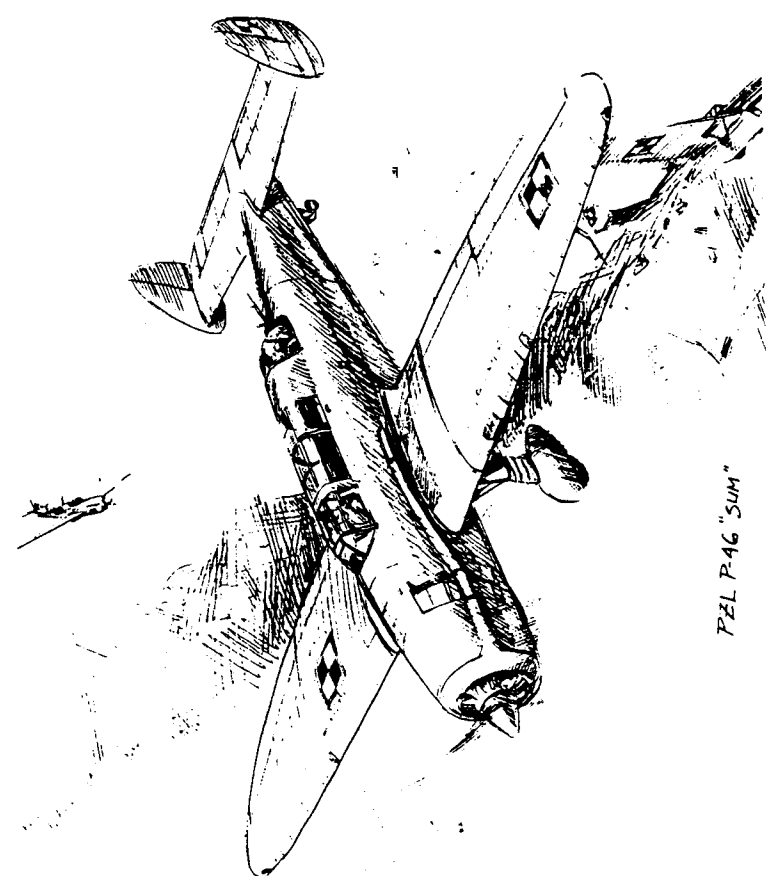
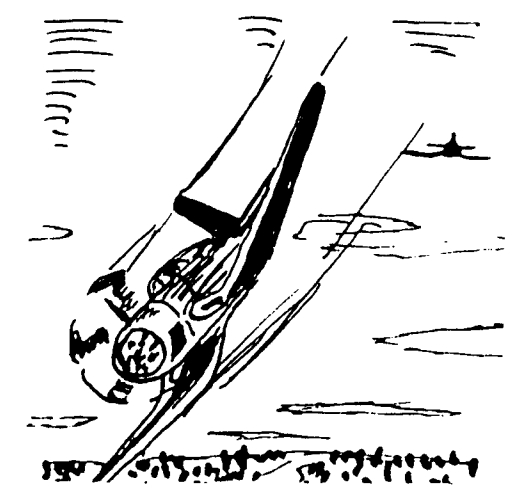

PZL P-46 'Sun'

THE TEXAN

In Accordance with our policy of bringing you Skysters only winners, we proudly present Tom Nallen, Jr's Texan which will really show the other Peanuts which way is up! Flick an orb over this 3-view Tom used. This little Sky Scrapper is a darn accurate model! According to the text in the October 1959 issue of M.A.N. her colors were all over Piper Pacer Cream, with red trim outlined with a black pin stripe. Black registration. A pretty nifty little ship, and an even better model. Better head for the hanger and get your own Texan skyborne as soon as you can.

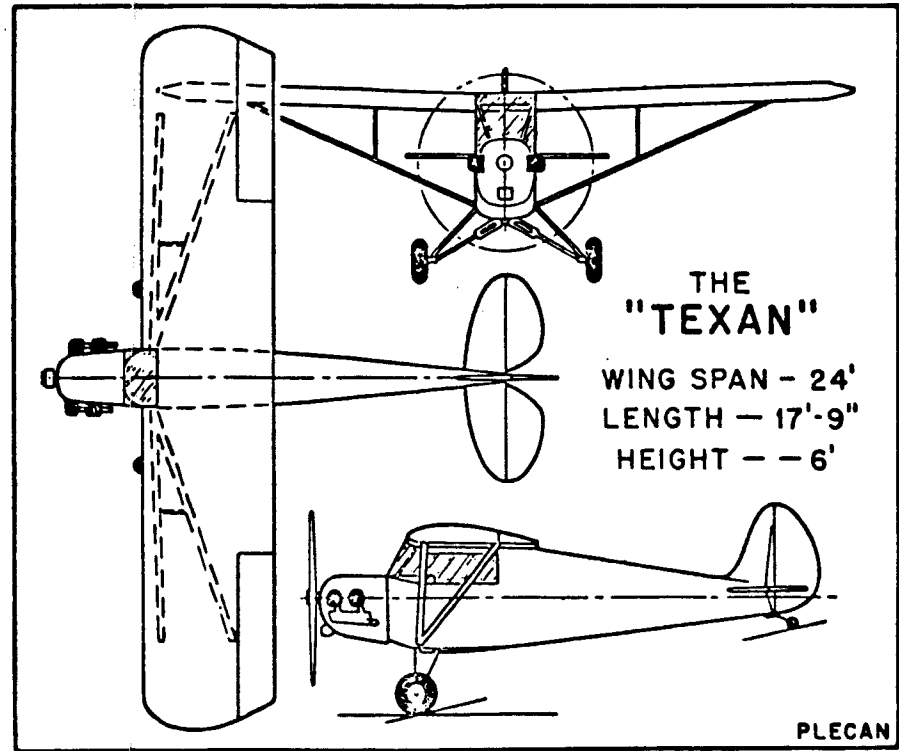

PLECAN

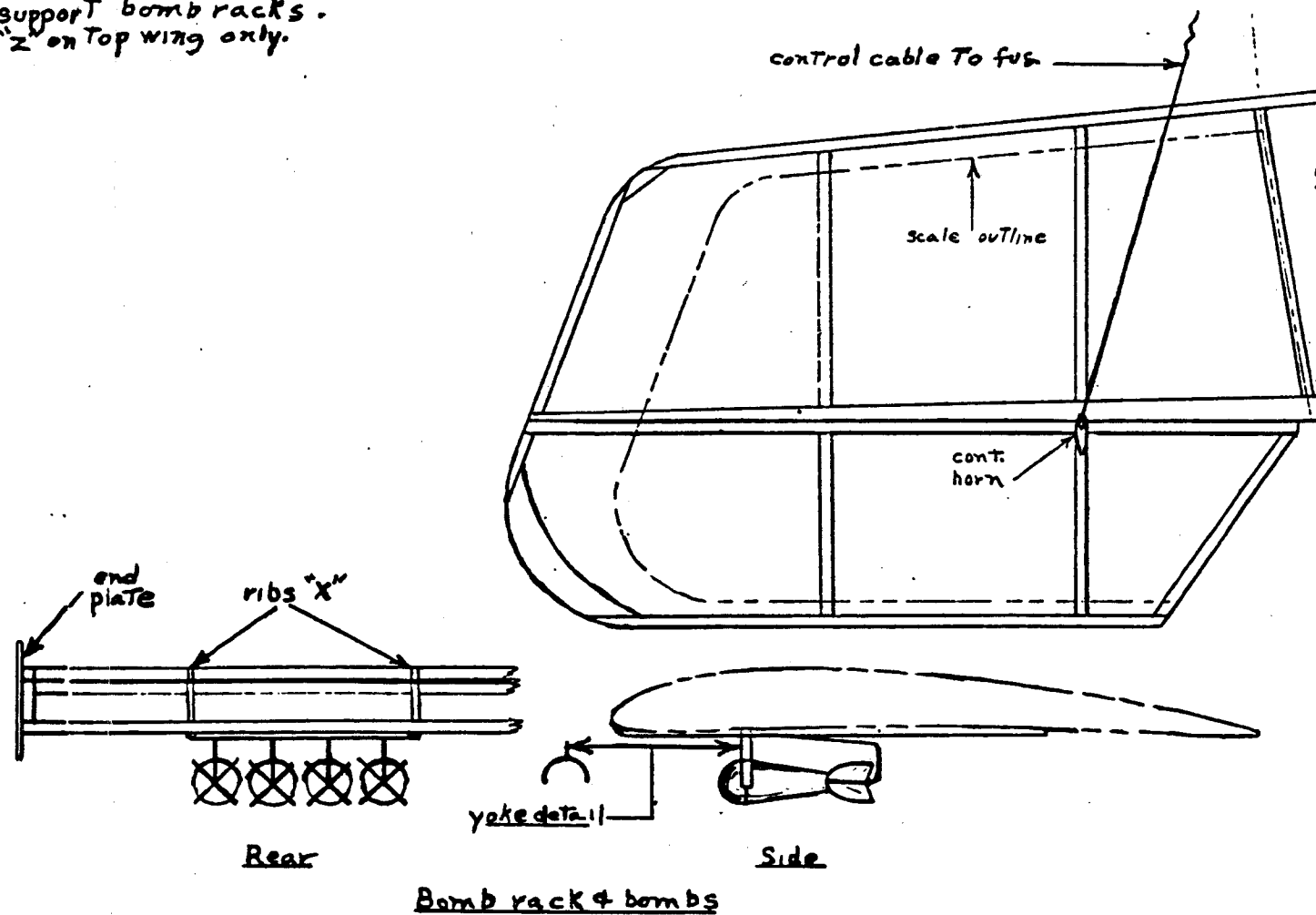
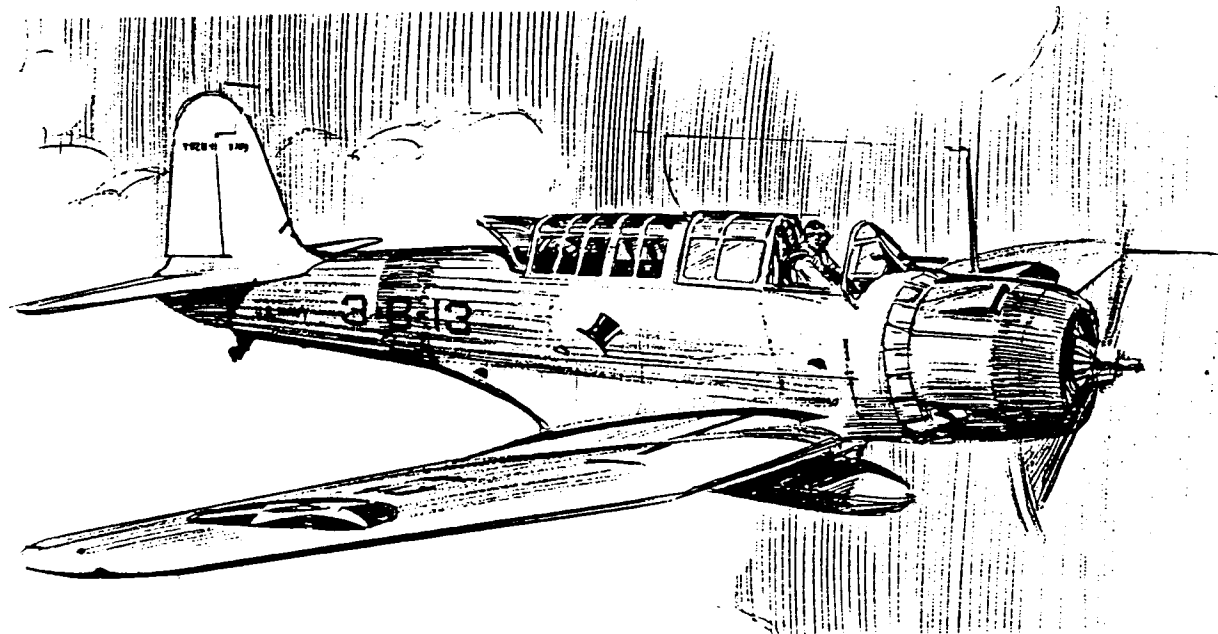
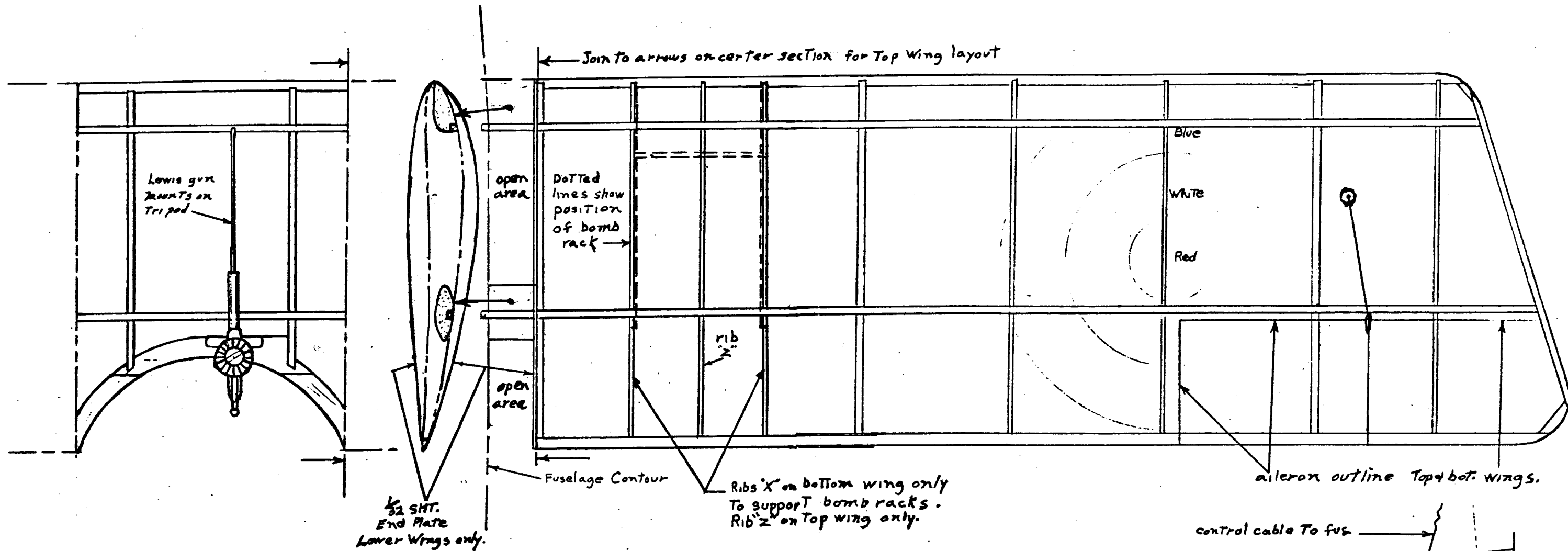

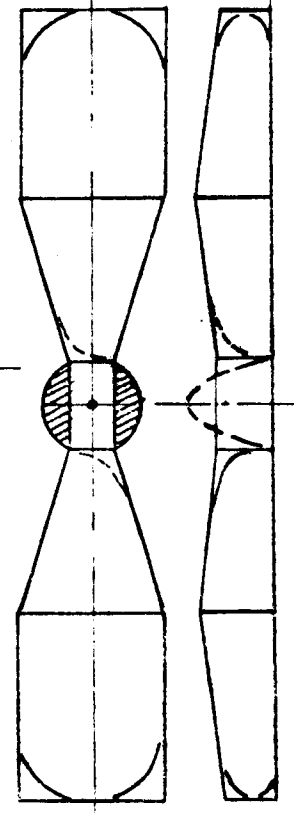
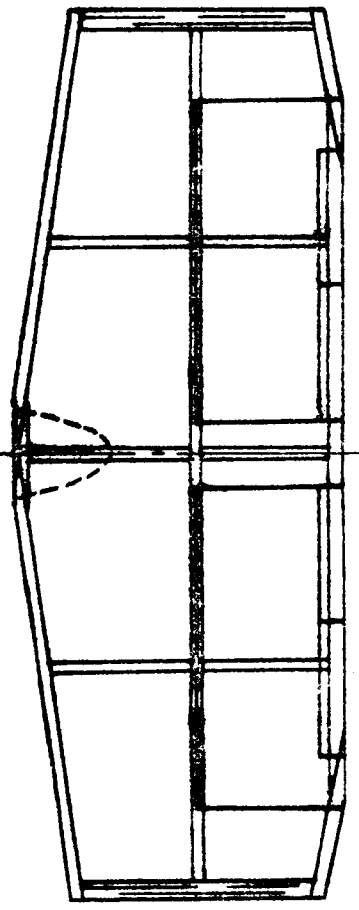
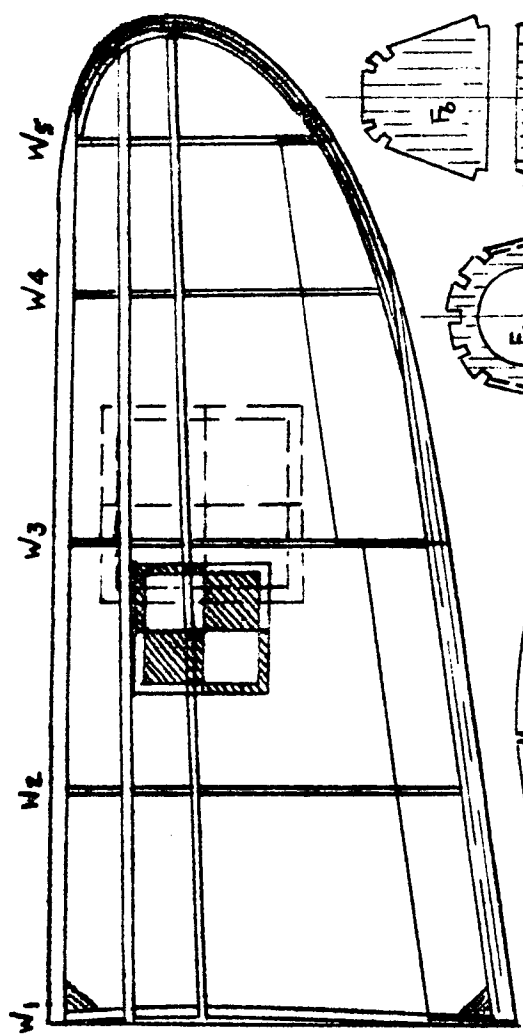

PROP BLANK

COLOR SCHEME : OLIVE GREEN TOP SURFACES
 & LANDING GEAR & VERT.
 STAB. LIGHT BLUE
 LOWER SURFACES

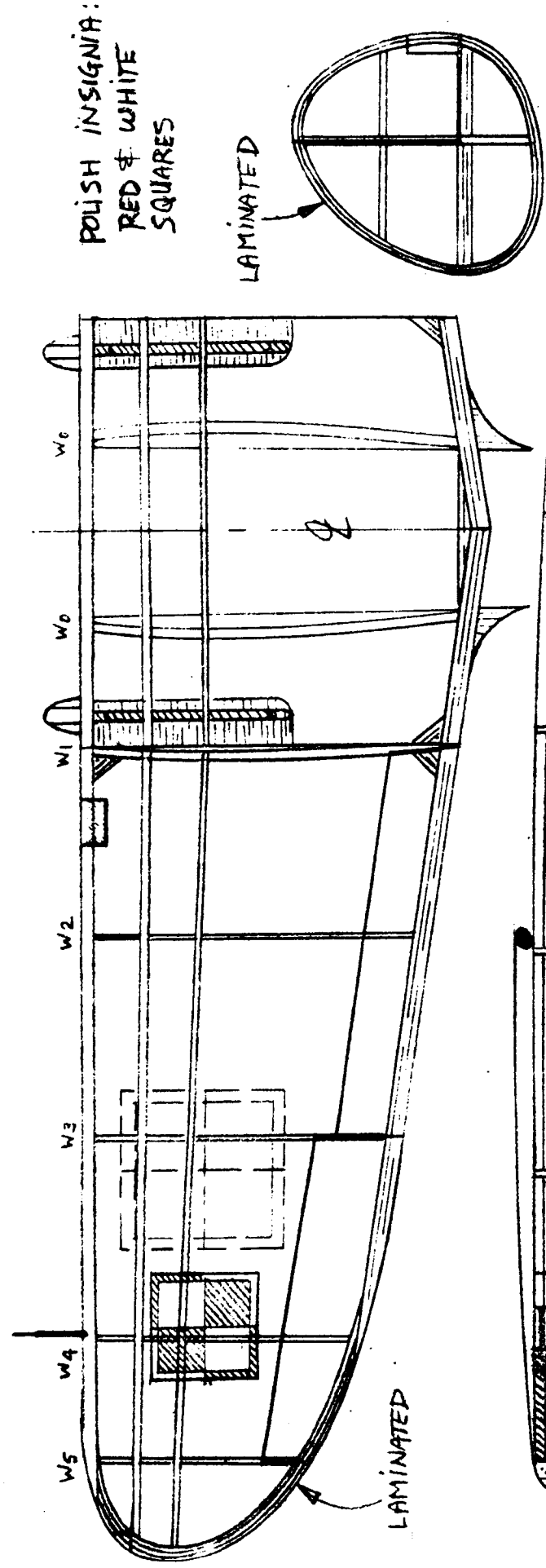
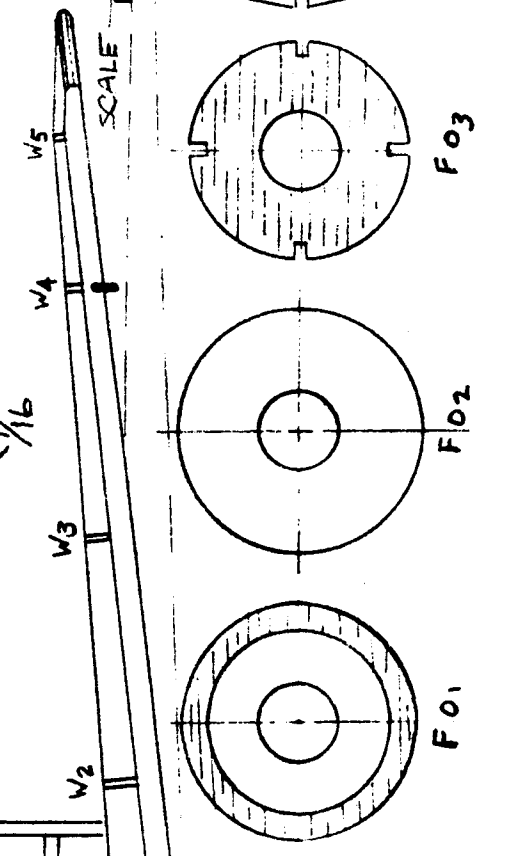
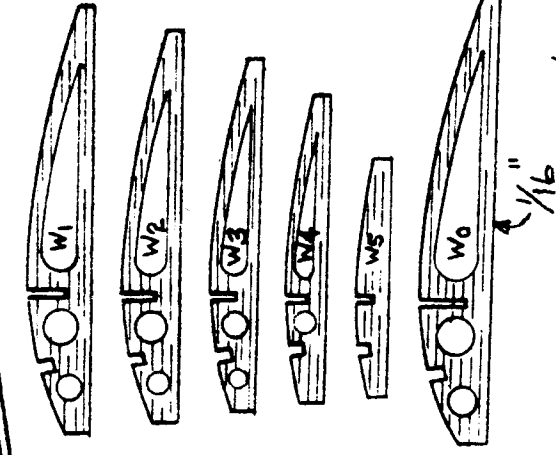
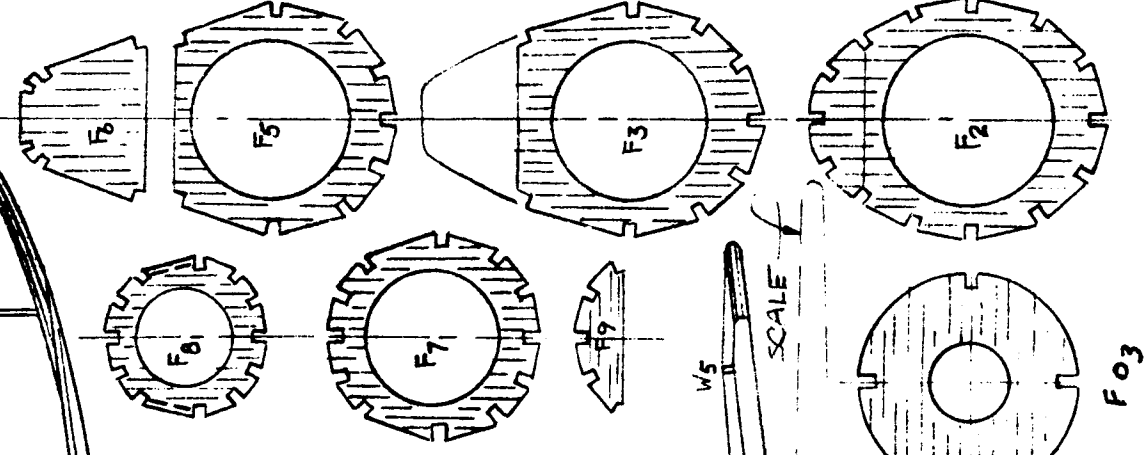

POLISH INSIGNIA:
 RED & WHITE
 SQUARES

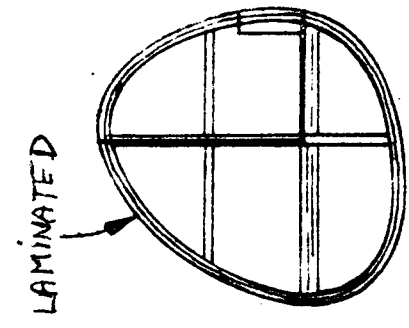

LAMINATED

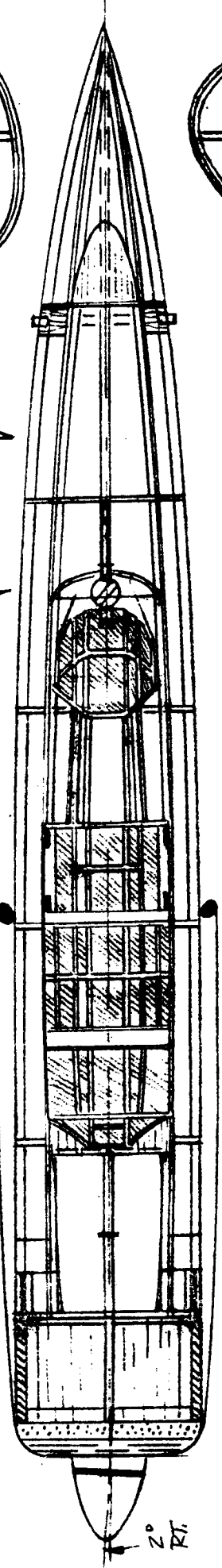

2° DOWN
 RT.

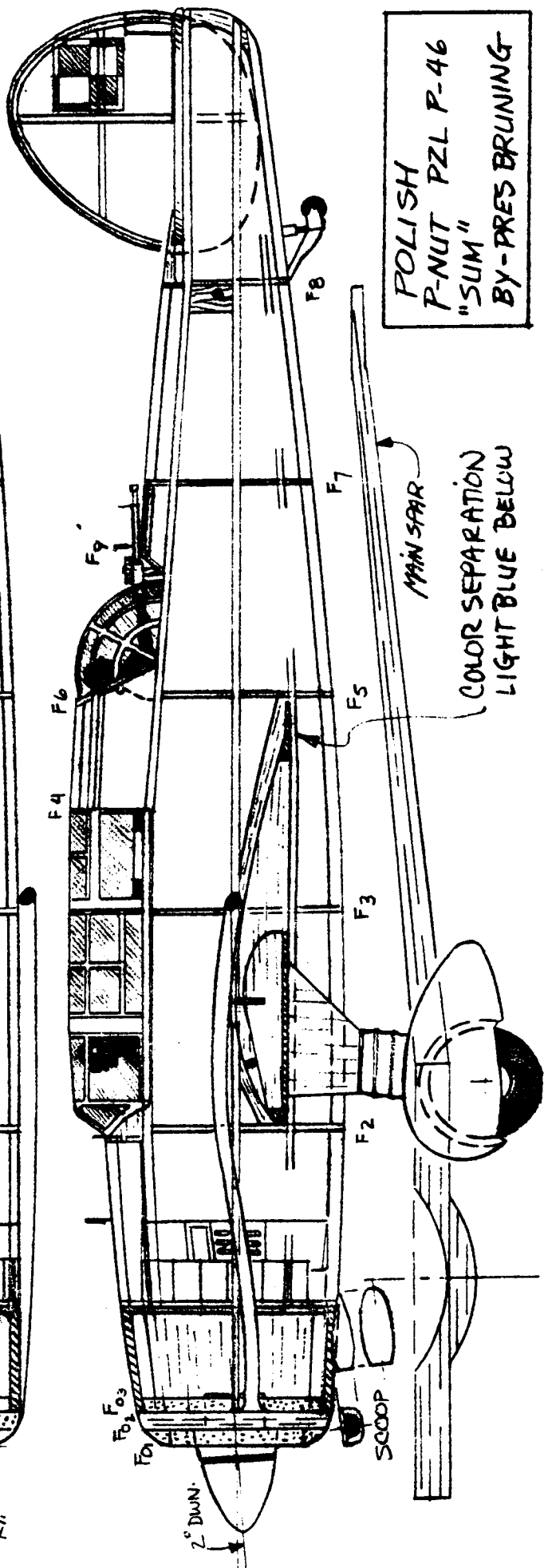

POLISH
 P-NUT PZL P-46
 "SUM"
 BY-PRES BRUNING

COLOR SEPARATION
 LIGHT BLUE BELOW

MAIN SPAR

SCOOP

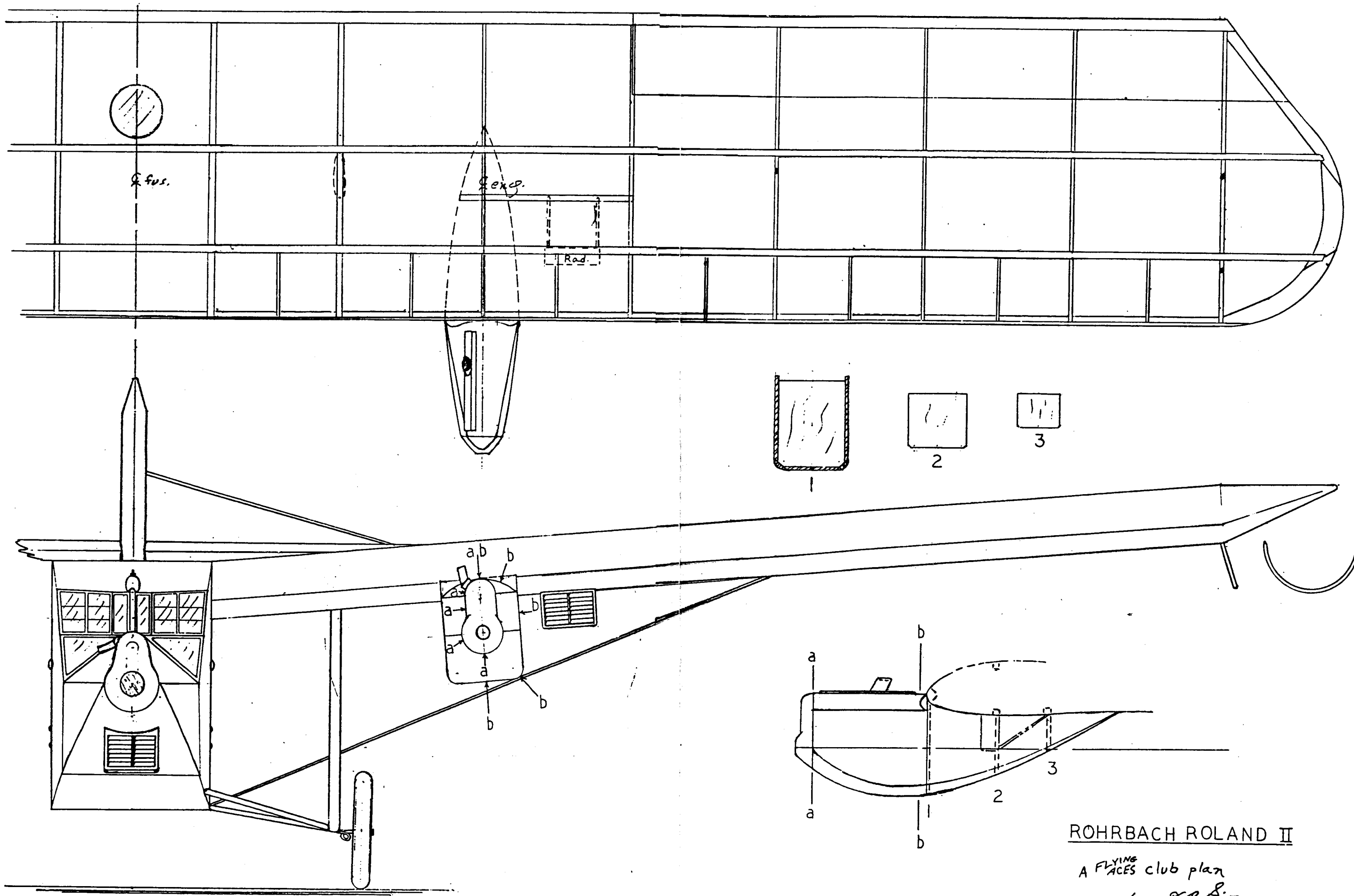

ROHRBACH ROLAND II

A FLYING club plan

10/70 R.C.S. ✠

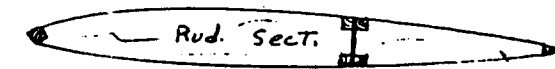
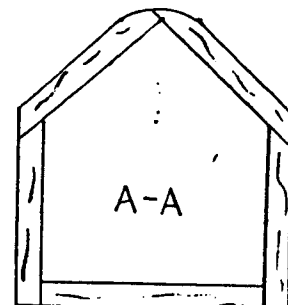
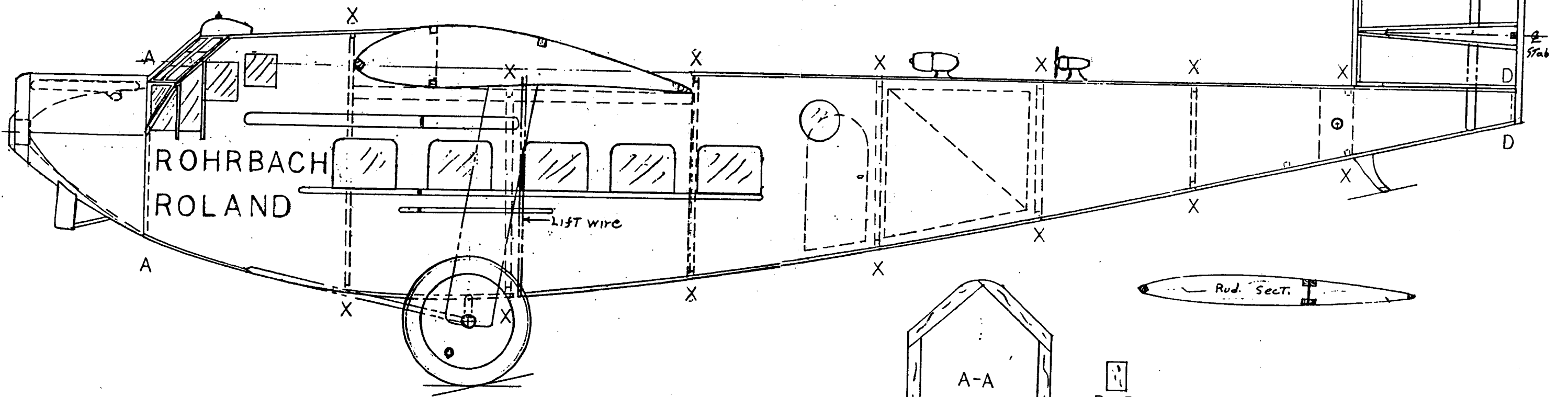
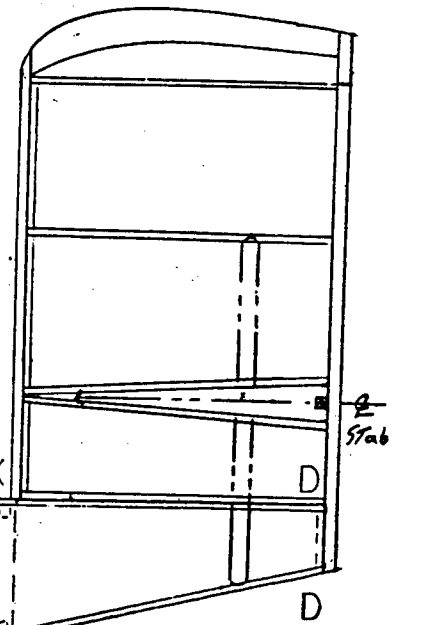
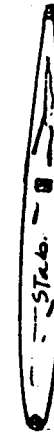
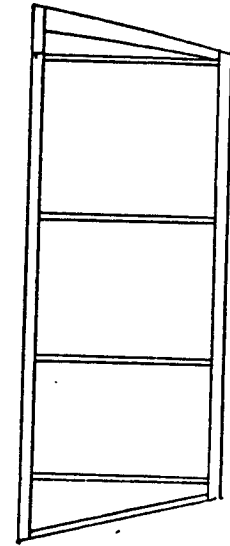
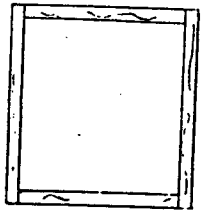
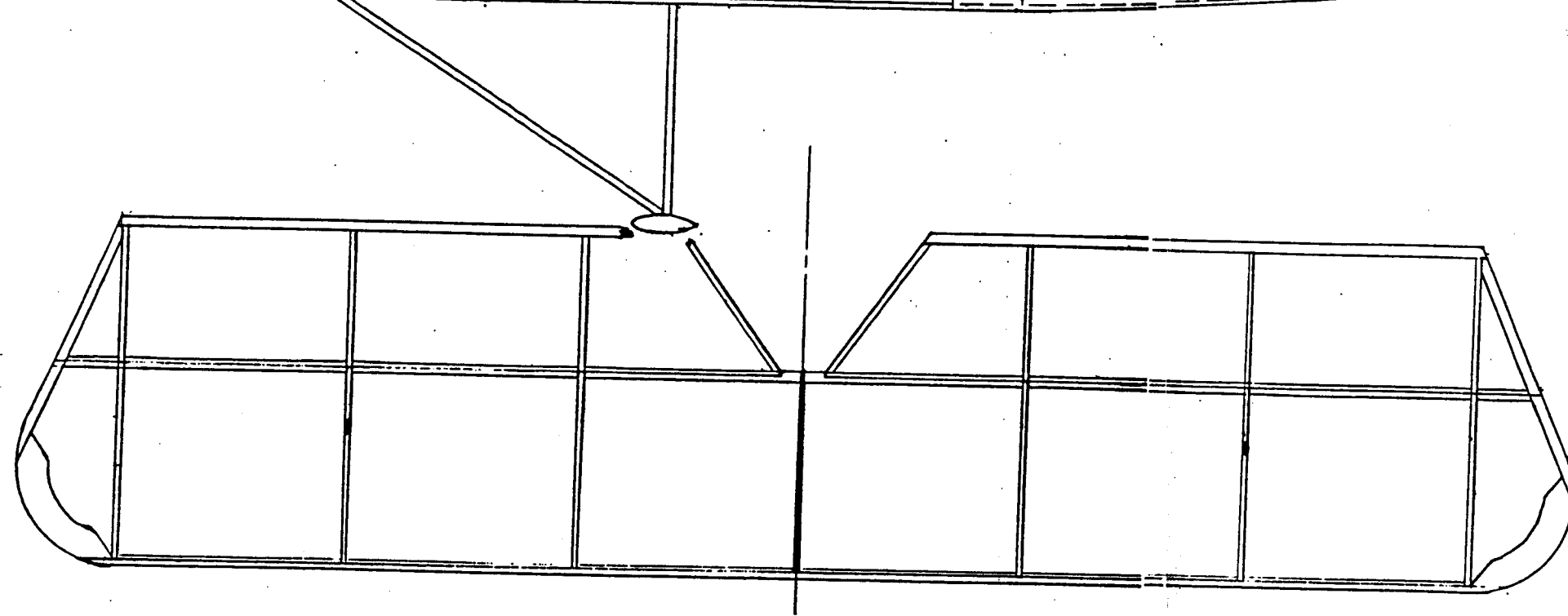
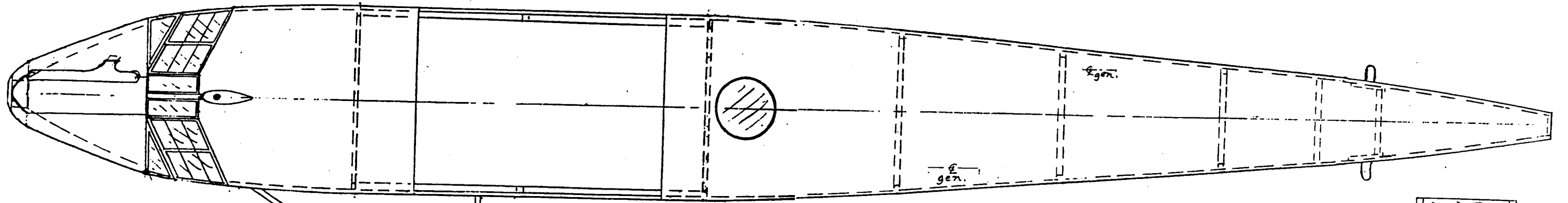

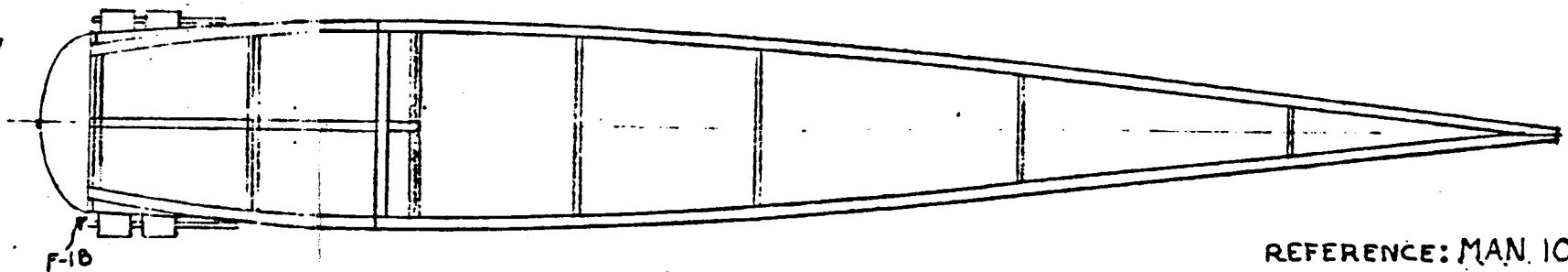
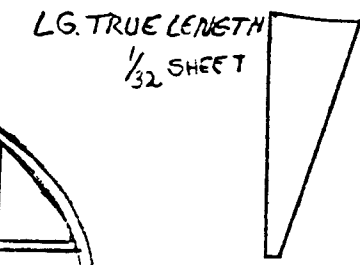
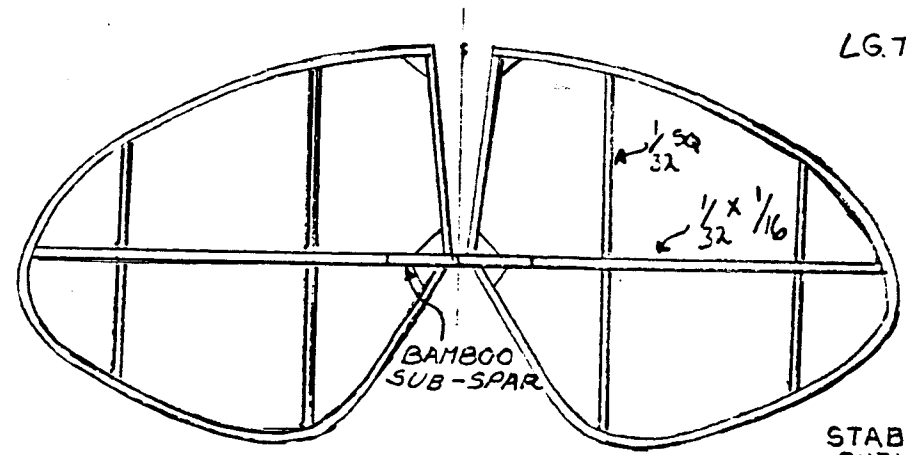
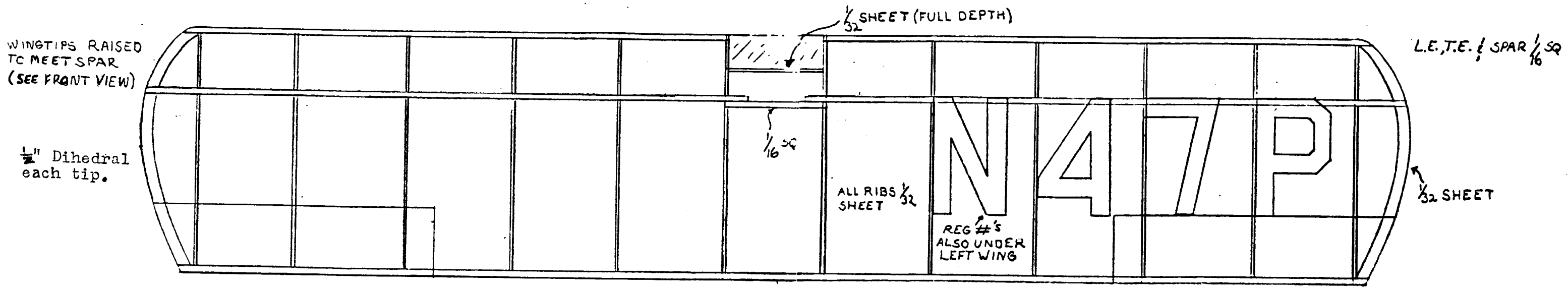

REFERENCE: MAN. 10/59 PG. 34

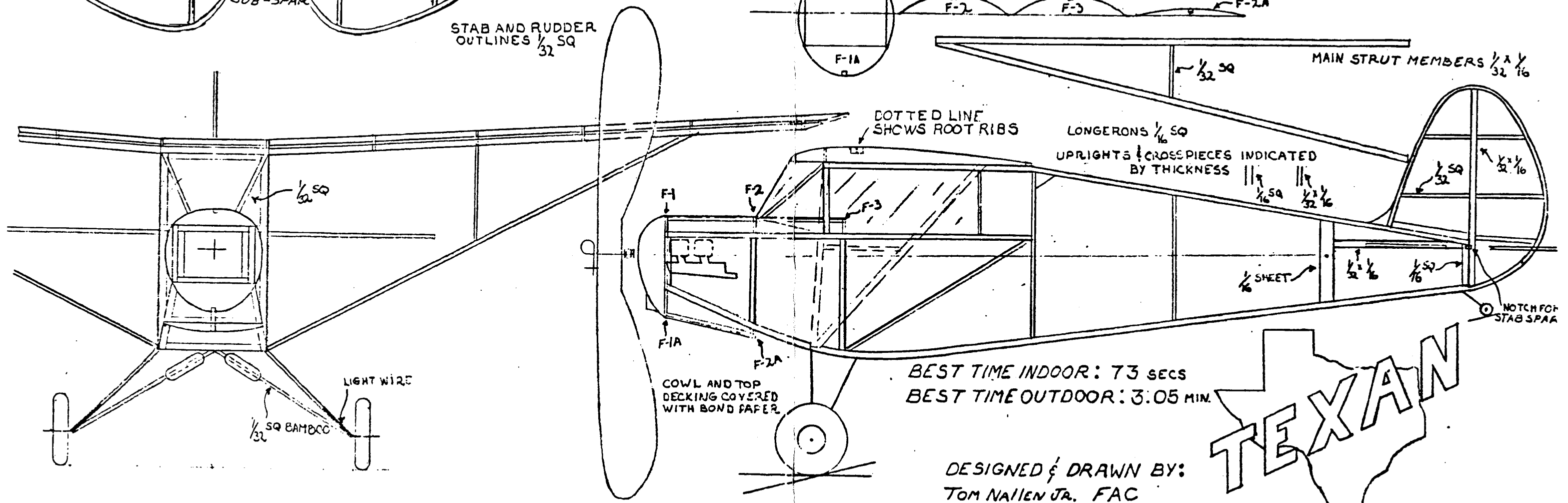
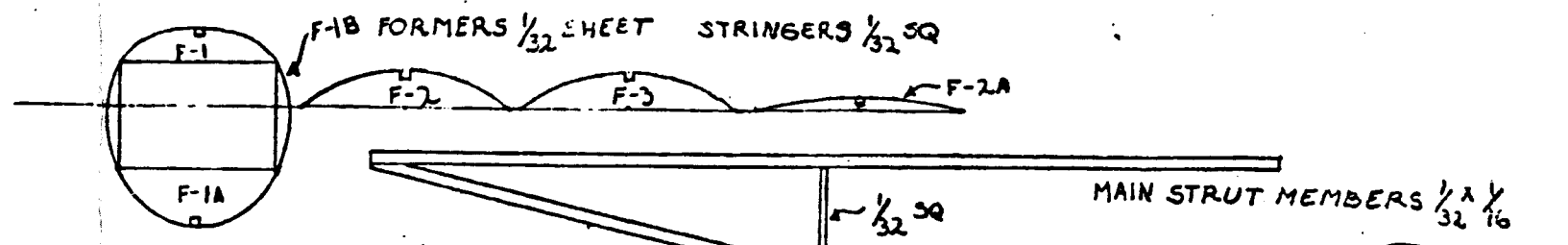

BEST TIME INDOOR: 73 SECS
 BEST TIME OUTDOOR: 3.05 MIN.

DESIGNED & DRAWN BY:
 TOM NALLEN JR. FAC

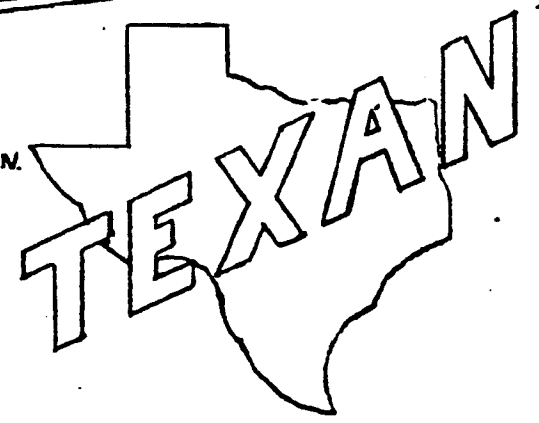

ROHRBACH ROLAND

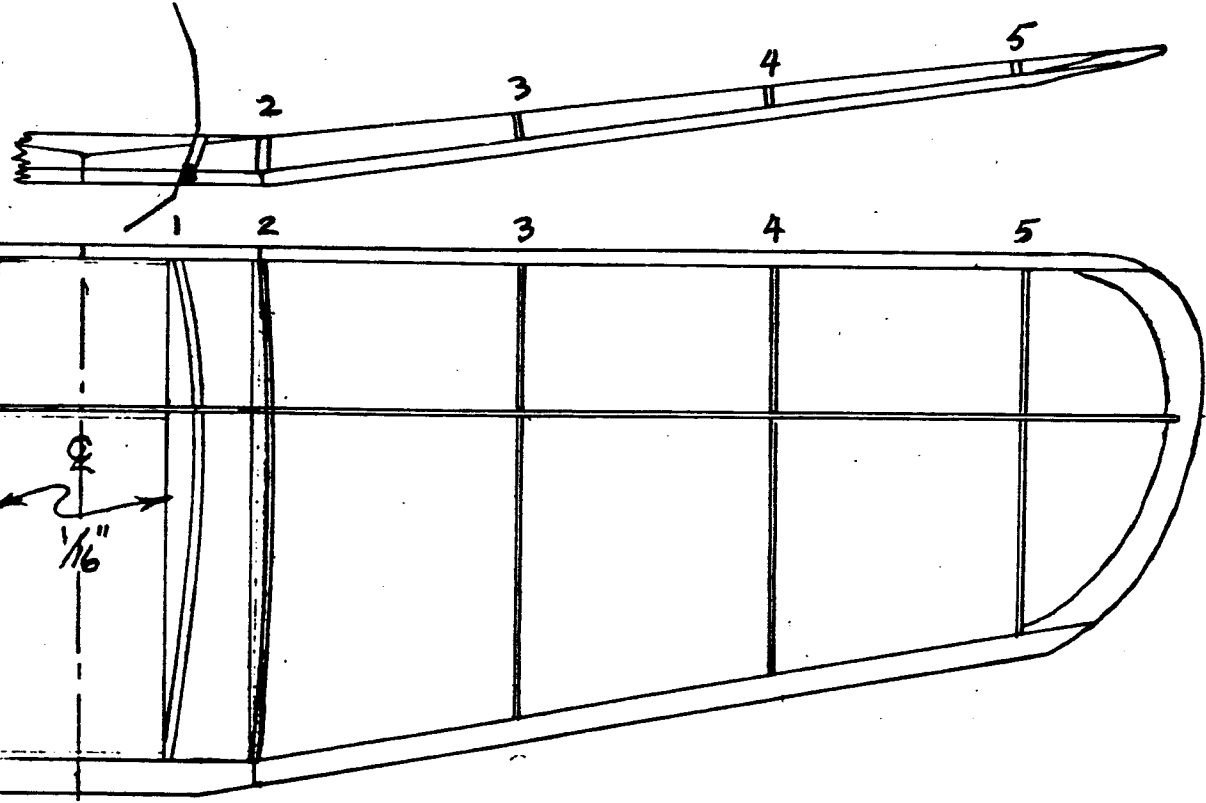

Next on the deadline is "Angular" Adolph Rohrbach's "Roland" air-liner. "Achtung, achtung," blares the loudspeaker at Templehof. "All passengers for Munich und Augsburg board liner number seeben." Yep fellows, this box was one of Lufthansa's early beer and sausage earners. Here is your chance to earn greater rewards in FAC competition! Look at the bonus points those tri-motors win you! But then there is the 0 points for the high wing cabin configuration! Oh well, it is a nice crate anyhow! Why not try one? Here's a few tips to help you interpret the plans.

Fuselage sides are 1/32 sheet balsa with 1/16 stiffeners glued to the inside surfaces at sections X-X. Section A-A at the nose gets 1/16 X 1/8 stiffeners. Cabin windows are pre-cutout in the 1/32 sheet sides and top. Once sides are joined in usual fashion, 1/32 sheet is laid on top and bottom and trimmed off even with sides. Pilot's cabin frame is built up of 1/32 squares. All celluloid is attached inside the fuselage. Not easy, but rewarding in appearance. Nose from A-A forward is carved from solid balsa and hollowed out. A small nose plug was fitted on the original model and the entire engine cowl from A-A forward was removable to facilitate winding. Thrustline adjustments were made by shimming the nose button.

Engine nacelles are solid and hollowed from B-B forward. Aft of this they are made of 1/32 sheet sides with soft 1/8 sheet bottom sanded to shape. Radiators were built up of 1/32 sheet outline with a railroad stock bass wood "clapboard" stock cut to fit in front to represent shutters.

Landing gear "v" is music wire covered with black insulation stripped from electrical wire. Girthy oleo balsa strut is slotted to allow wire struts to flex. Lift wire is a strip of bamboo. The remainder of the structure is standard procedure.

Perhaps better performance might be gained by reducing the thickness of the airfoil a bit. Although the one shown on the plan is very close to scale. A thinner one, if not carried to extremes, would not mar the appearance. Performance of the F.A.C. test lab model was mediocre, although an eye pleaser.

Color scheme is all over silver with black engine cowls, struts, and radiator shells. Radiator shutters were silver. "ROHRBACH ROLAND" is also black as would be the German civil registration if it were known. Photos seen for reference were works photos and no registry was allotted at that time. One truly comforting feature is the resistance to damage due to blown motors with this baby! Try one?

G-G

D-D

E-E

H

A-A

B-B

C-C

VOUGHT OS2U-2 "KINGFISHER"

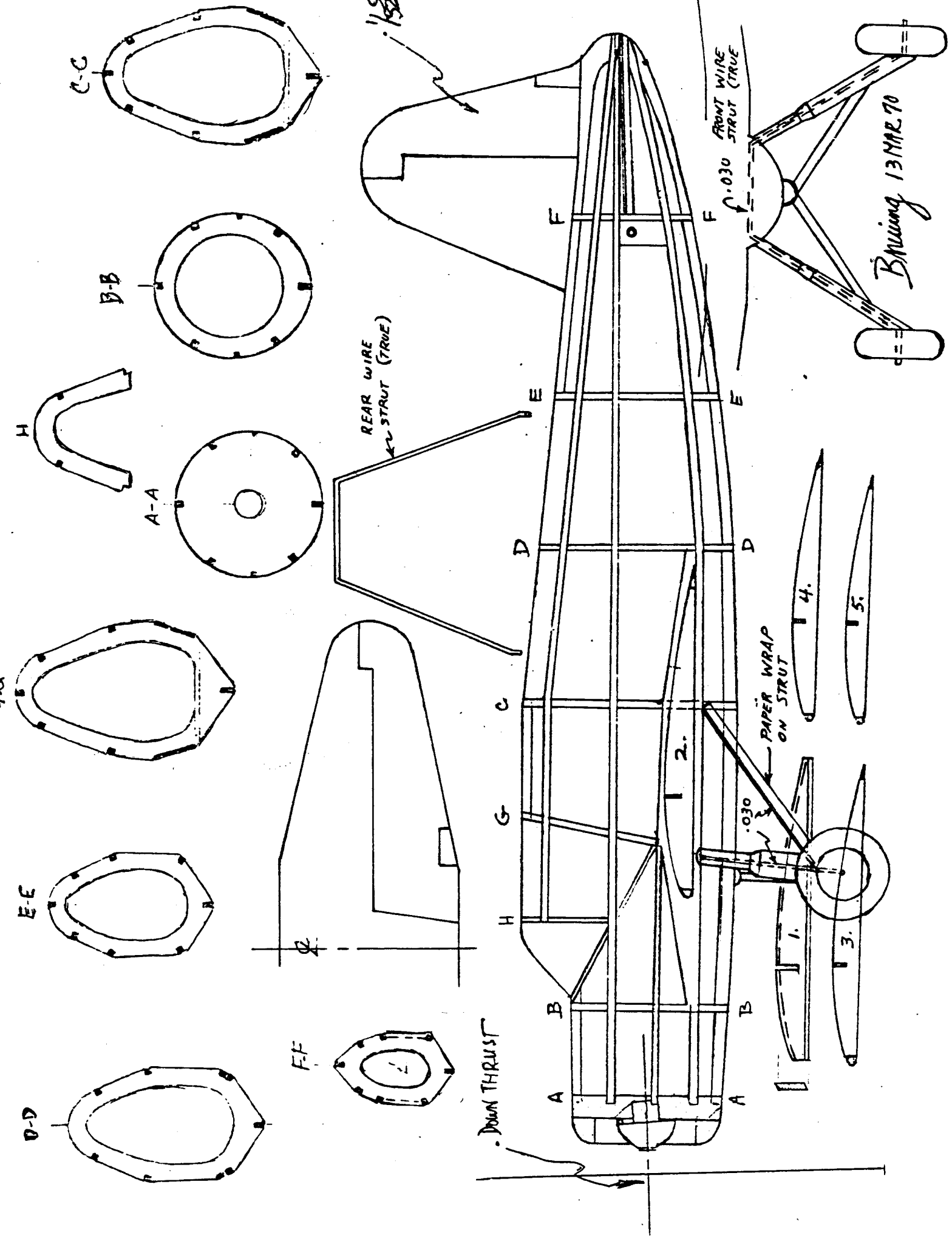

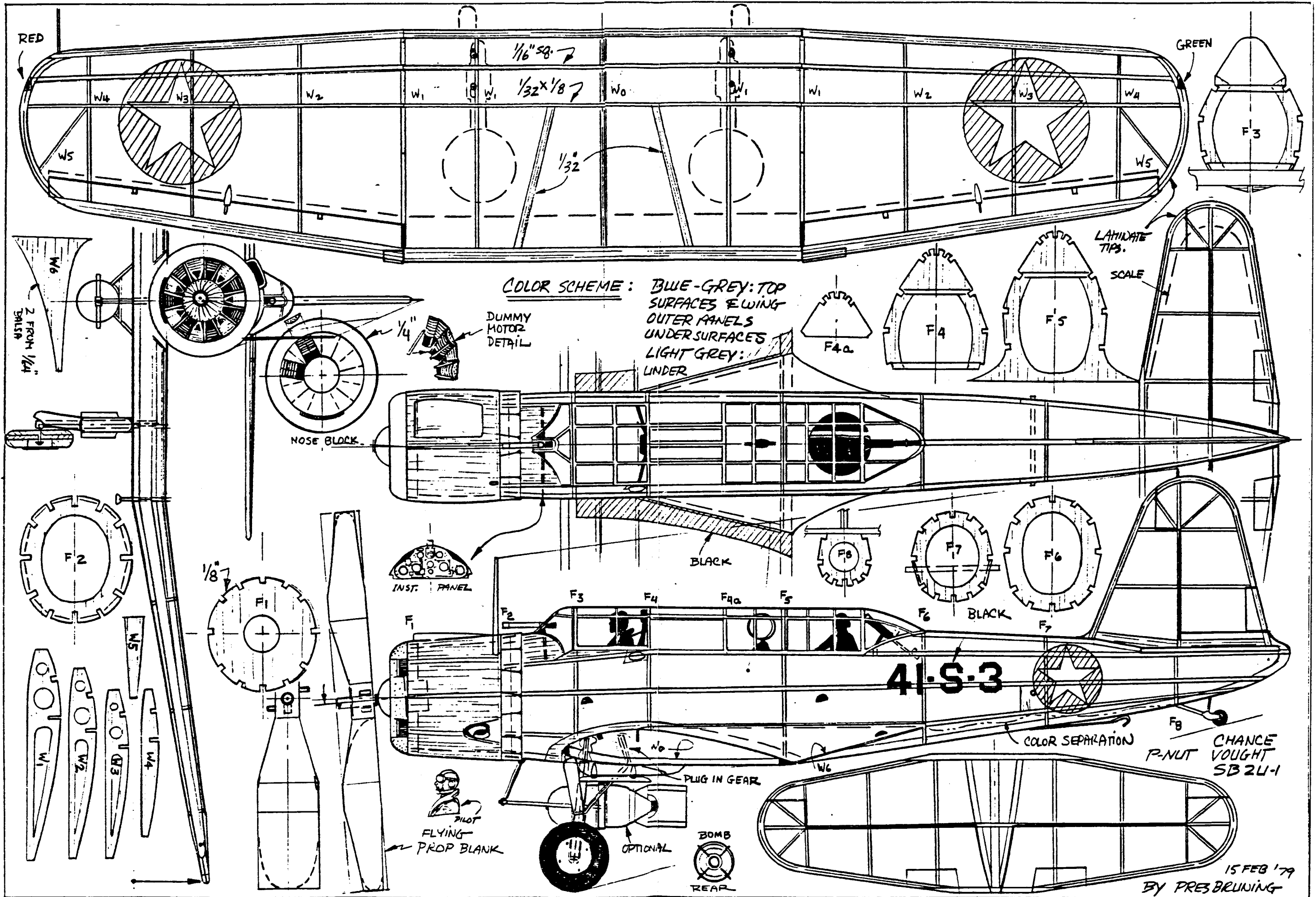

RED

GREEN

COLOR SCHEME: BLUE-GREY: TOP SURFACES & WING OUTER PANELS UNDER SURFACES LIGHT GREY: LINDER

DUMMY MOTOR DETAIL

NOSTRIL

INST. PANEL

BLACK

BLACK

COLOR SEPARATION

CHANGE VOUGHT SB 24-1 P-NUT

PILOT FLYING PROP BLANK

OPTIONAL

BOMB REAR

41-S-3

15 FEB '79 BY PRES BRUNING