

FLYING ACES

Club

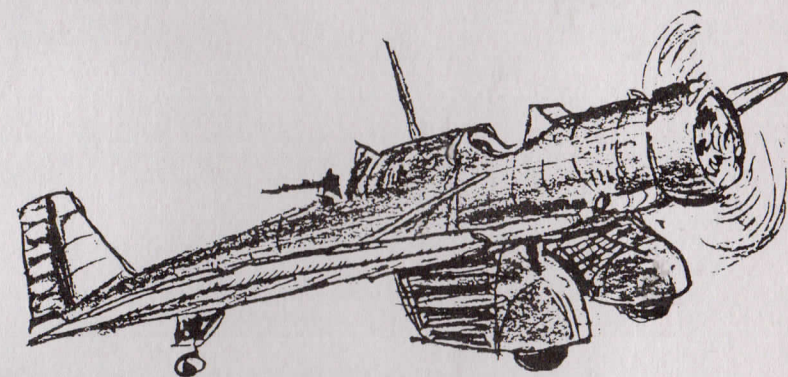

PLAN PACKET

NO. 3

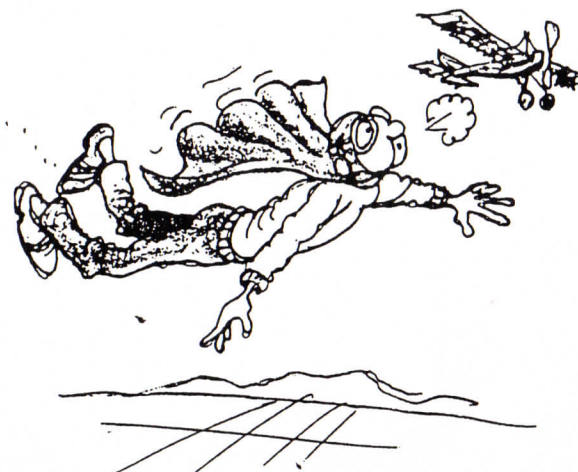

FLYING ACES

3301 Cindy Lane
Erie, PA 16506

Dear Fellow FACers,

Thanks for purchasing the FAC Plan Packet #3. We hope that you like it and will build some of the models herein. Remember, some of these plans were drawn several years ago and modelling has changed rather drastically since then.

Thrust adjustments, rear peg locations, etc., are now left up to the modeler himself, in most cases. Most of you have your own systems for these things anyway. Set them up in the way that works best for you.

There are ten plans in this packet, sixteen sheets (11 X 17) with nothing printed on the back so that you can build from them right out of the packet.

If you build any of these models please send us a photo of your model and we will print it in the newsletter.

Now let's get to the building board.....

BUILD--FLY--WIN...EFF--AAA--CEEEE!!!

Table of contents;

1. Mitsubishi J2M3 "Raider" by Pres Bruning 13" span.
2. Alco Sportplane by Dave Stott 13" span.
3. Southern Martlet by J. Whatmore 12½" span.
4. Blackburn "Baby" (floats) by Dave Stott 12½" span.
5. Delgado "Flash" by Pres Bruning 13" span.
6. Bellanca CD by Dave Stott 21½" span.
7. Cranwell C.L.A.3 by Nick Peppiat 12½" span.
8. Fokker V-21--V-23 by Dave Smith 13" span.
9. Fiat CR-42 by Pres Bruning 20½" span.
10. Polish P.W.S-11 by Pres Bruning 13" span.

This plan packet is dedicated to all those FACers that have contributed to the newsletter over the years.

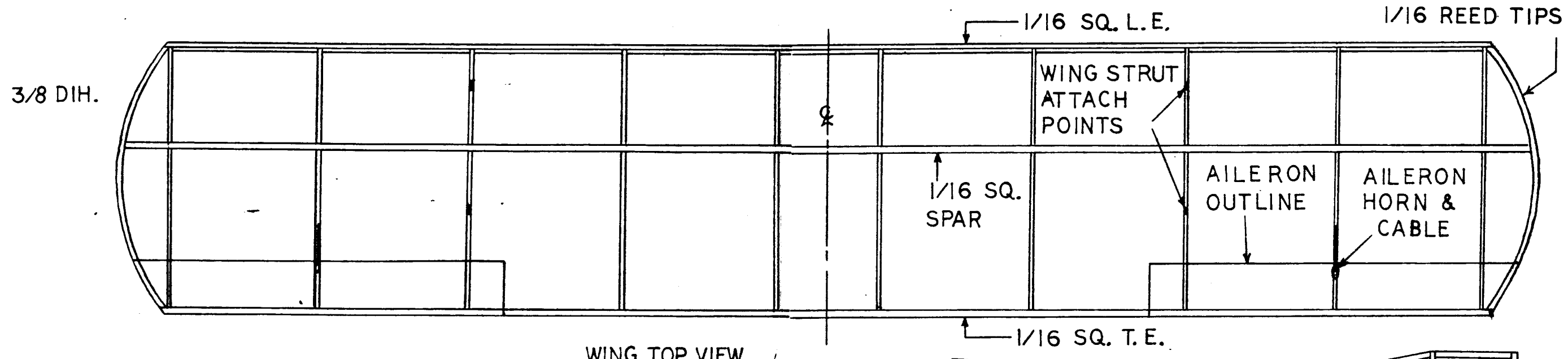

WING TOP VIEW

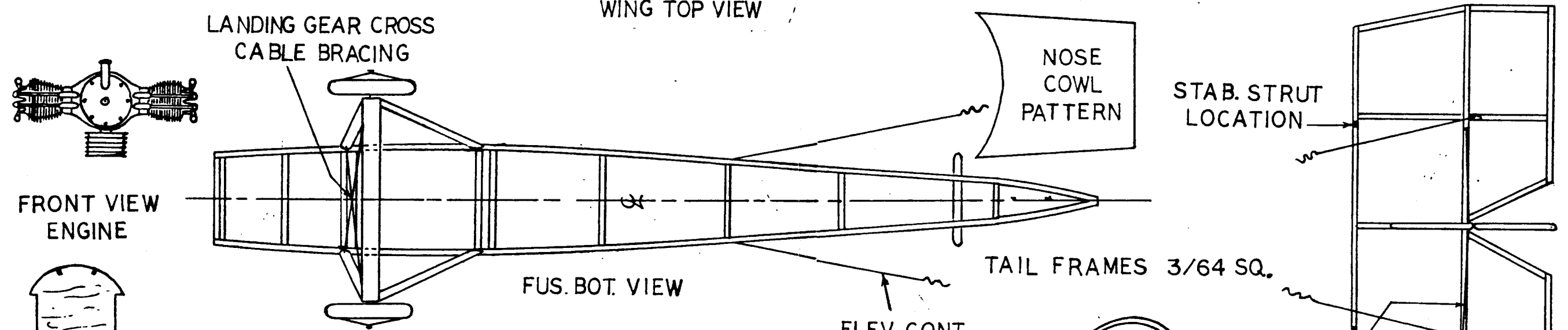

FUS. BOT. VIEW

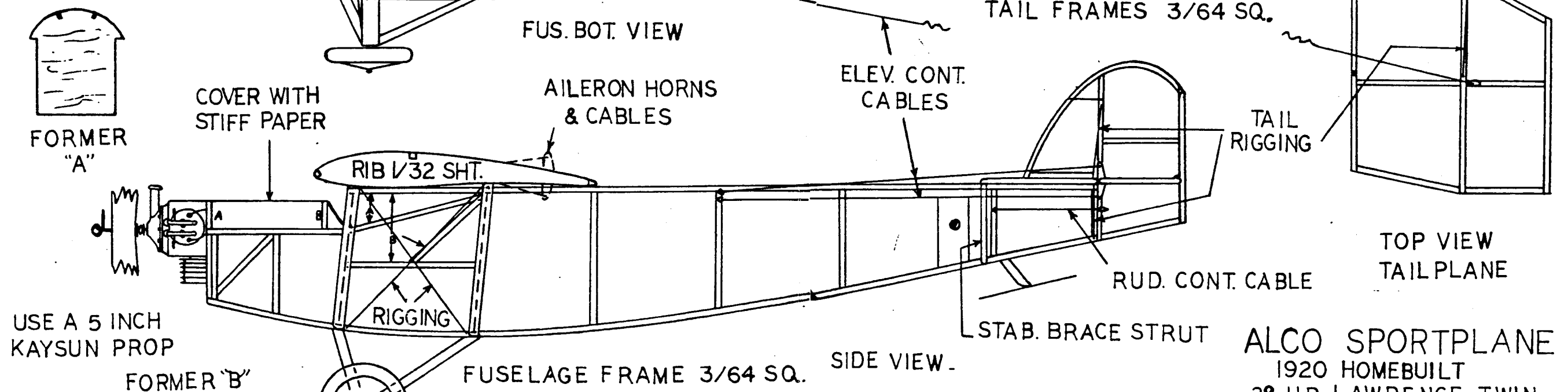

SIDE VIEW.

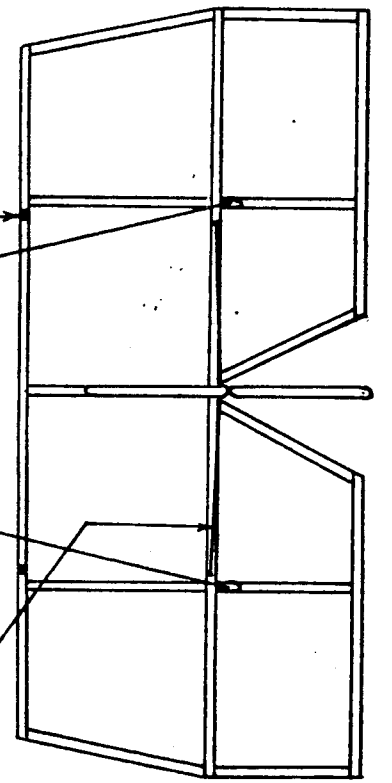

USE A 5 INCH KAYSUN PROP



CABIN IS OPEN BETWEEN ARROWS "A" ON R.H. SIDE & ARROWS "B" ON L. H. SIDE. NO WINDSHIELD.

A FLYING ACES CLUB PLAN

ALCO SPORTPLANE
 1920 HOMEBUILT
 28 H.P. LAWRENCE TWIN
 1/2 IN. = 1 FT.
 1-69 D.STOTT *D.S.*

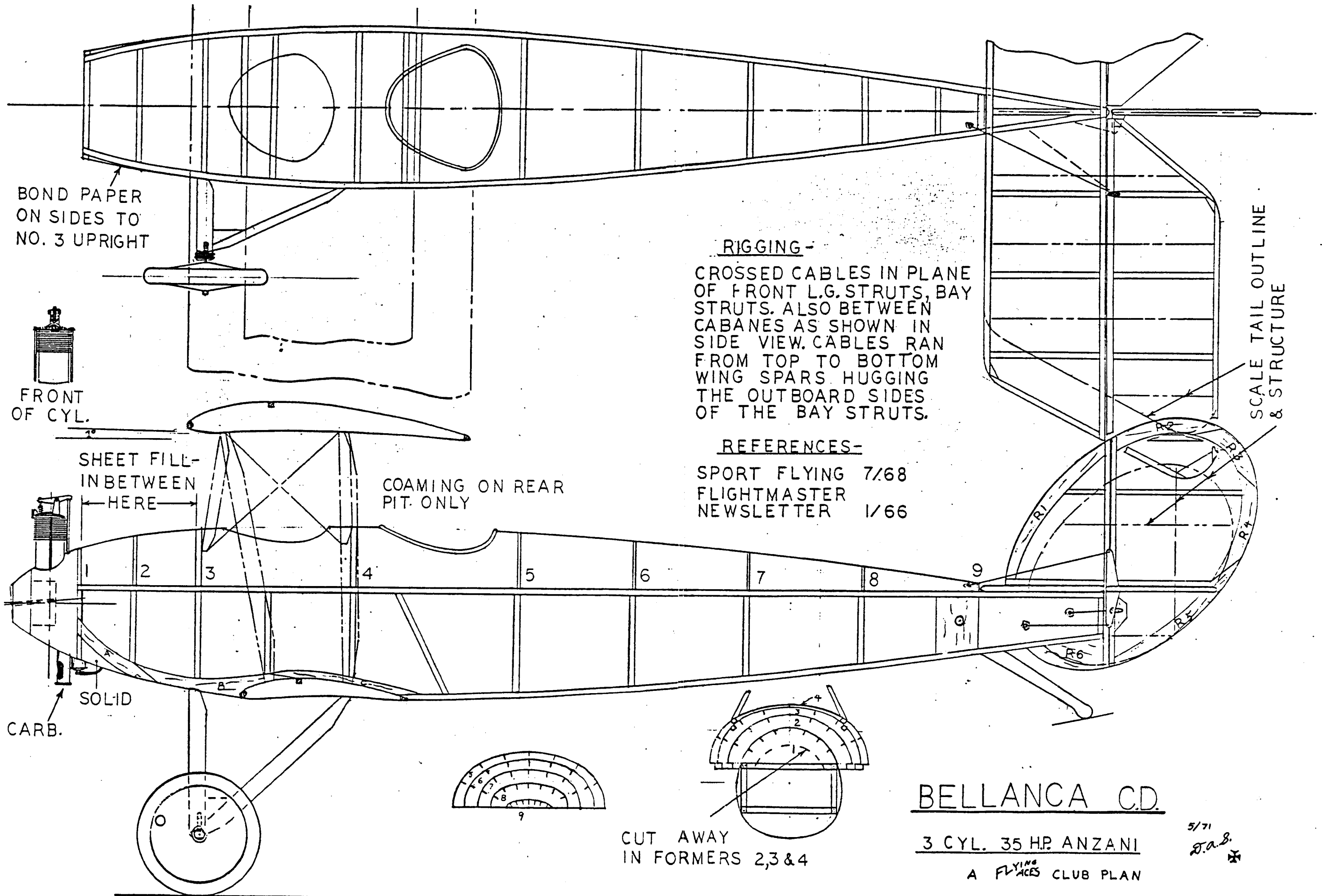

BOND PAPER ON SIDES TO NO. 3 UPRIGHT

FRONT OF CYL.

SHEET FILL-IN BETWEEN HERE

COAMING ON REAR PIT ONLY

CARB. SOLID

RIGGING -

CROSSED CABLES IN PLANE OF FRONT L.G. STRUTS, BAY STRUTS. ALSO BETWEEN CABANES AS SHOWN IN SIDE VIEW. CABLES RAN FROM TOP TO BOTTOM WING SPARS HUGGING THE OUTBOARD SIDES OF THE BAY STRUTS.

REFERENCES -

SPORT FLYING 7/68
 FLIGHTMASTER NEWSLETTER 1/66

SCALE TAIL OUTLINE & STRUCTURE

BELLANCA C.D.

3 CYL. 35 HP. ANZANI
 A FLYING CLUB PLAN

5/71
 D.A.B.

CUT AWAY IN FORMERS 2,3 & 4

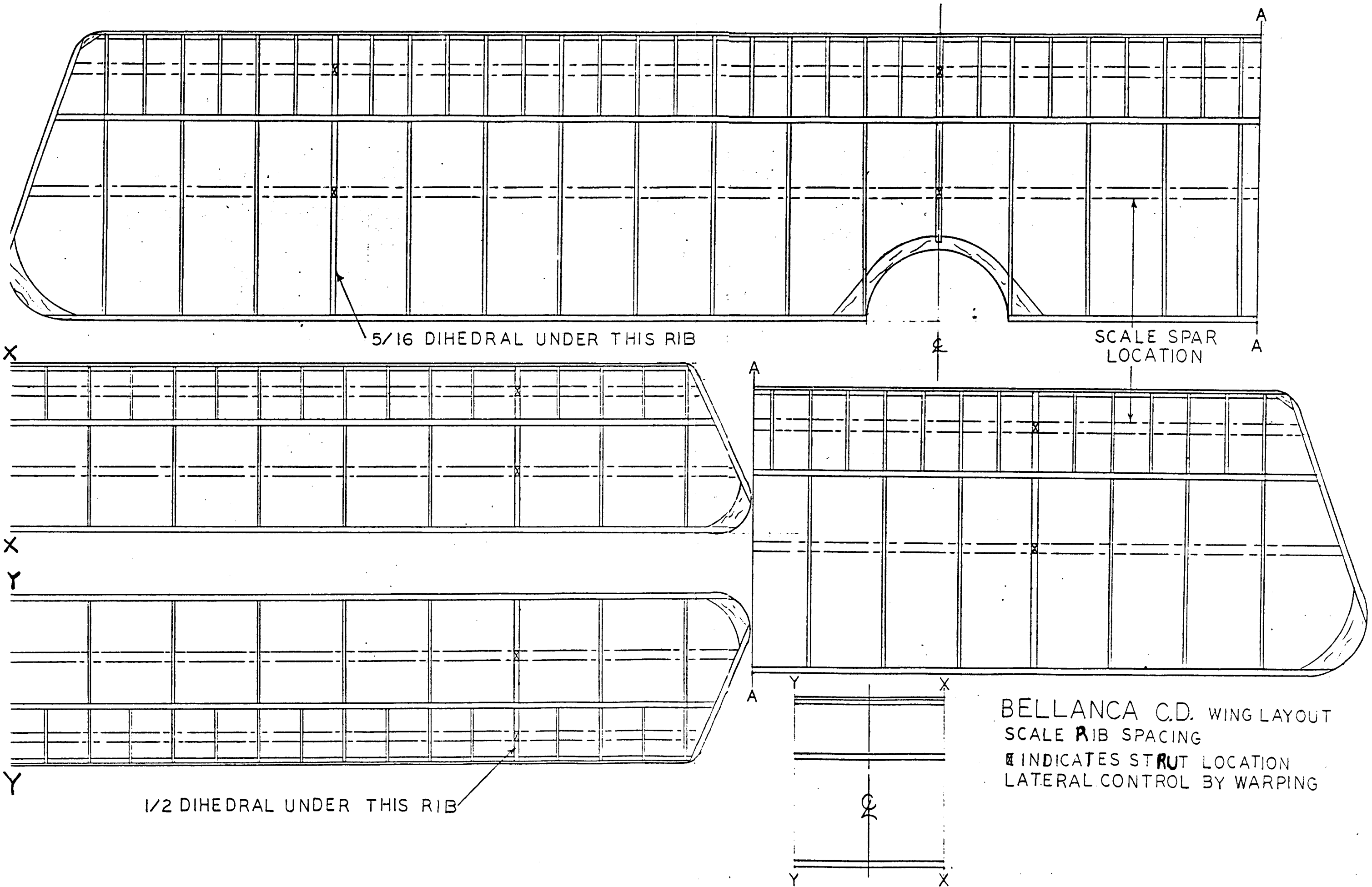

BLACKBURN BABY
PEANUT SCALE

by G.A.B. ✖

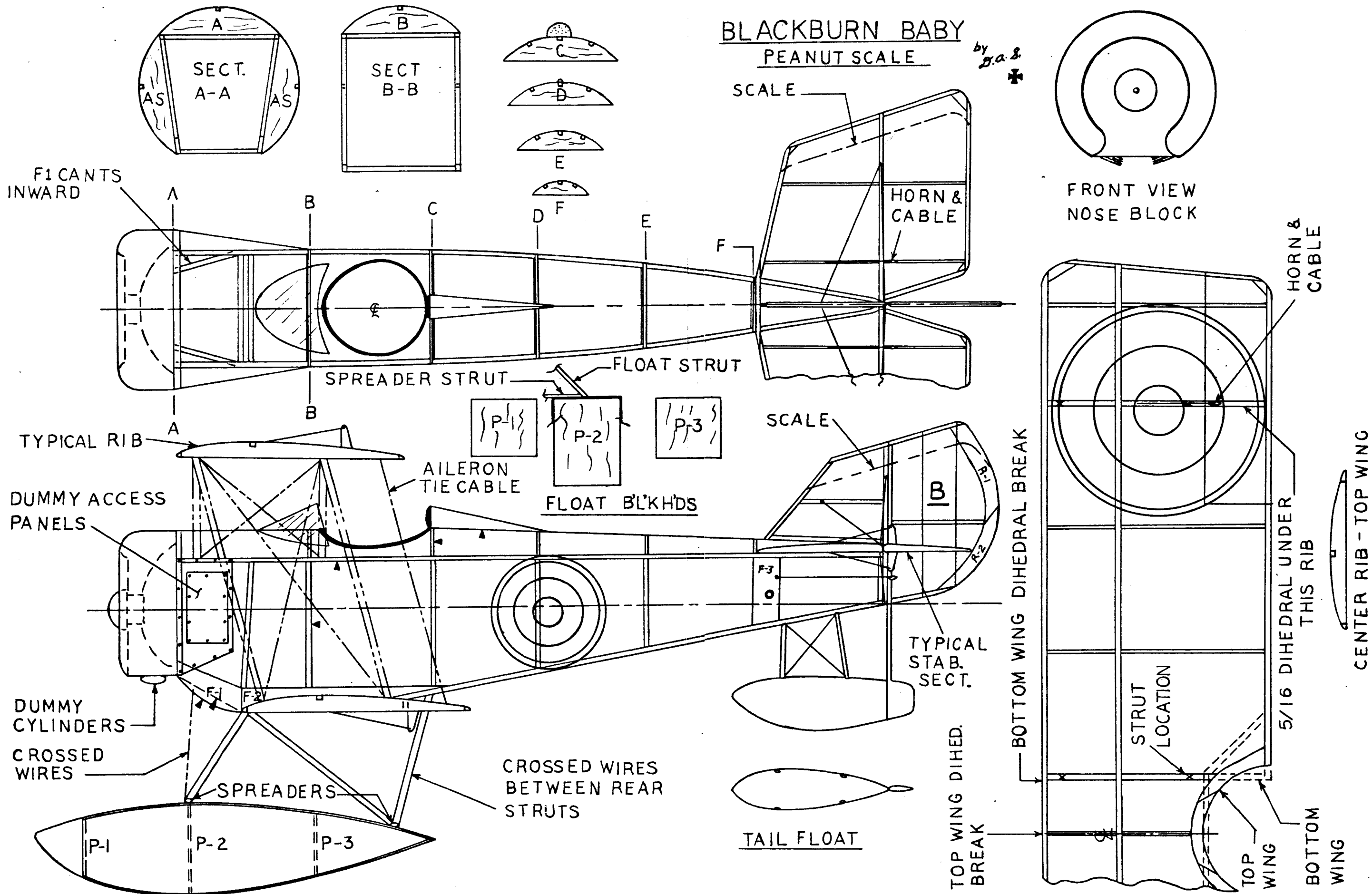

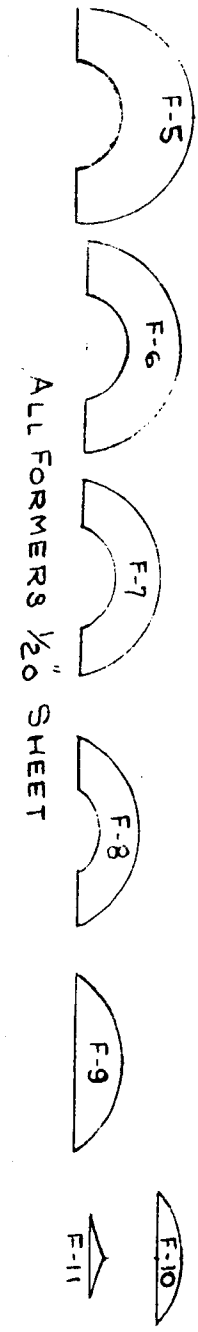
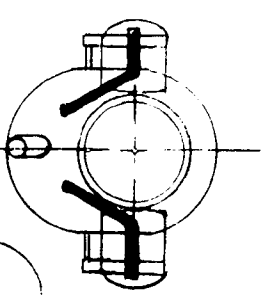
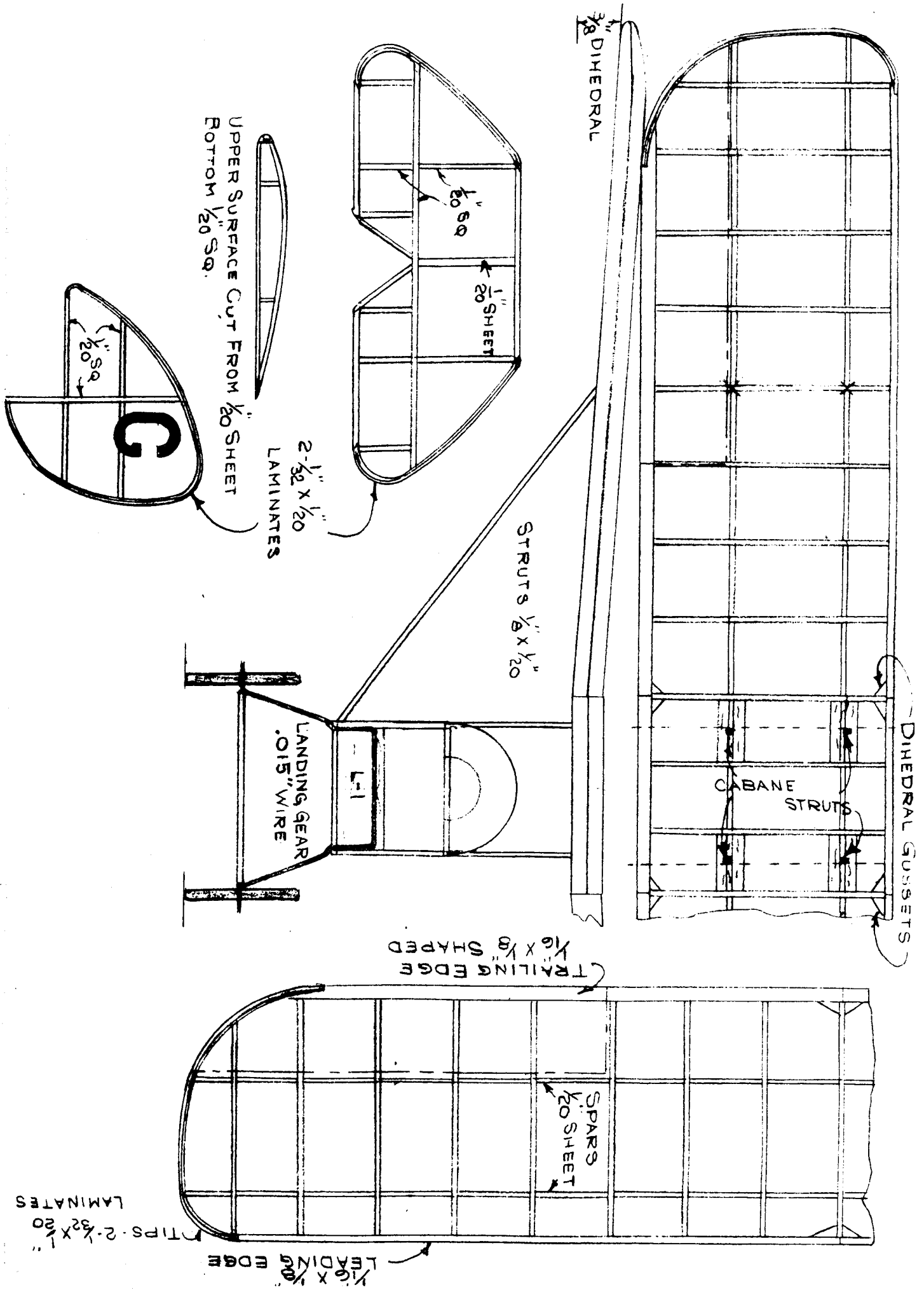

ALL FORMERS $\frac{1}{20}$ SHEET

NOTE! ALL $\frac{1}{20}$ SQ UNLESS SPECIFIED

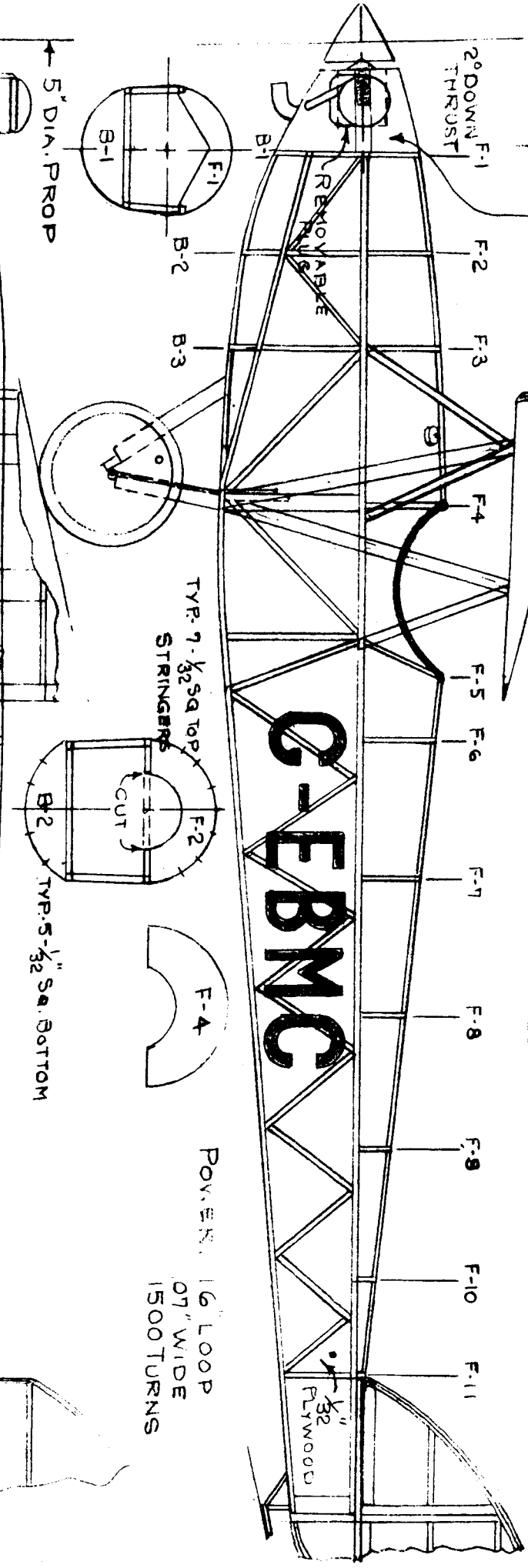

POWER: 16" LOOP
07" WIDE
1500 TURNS

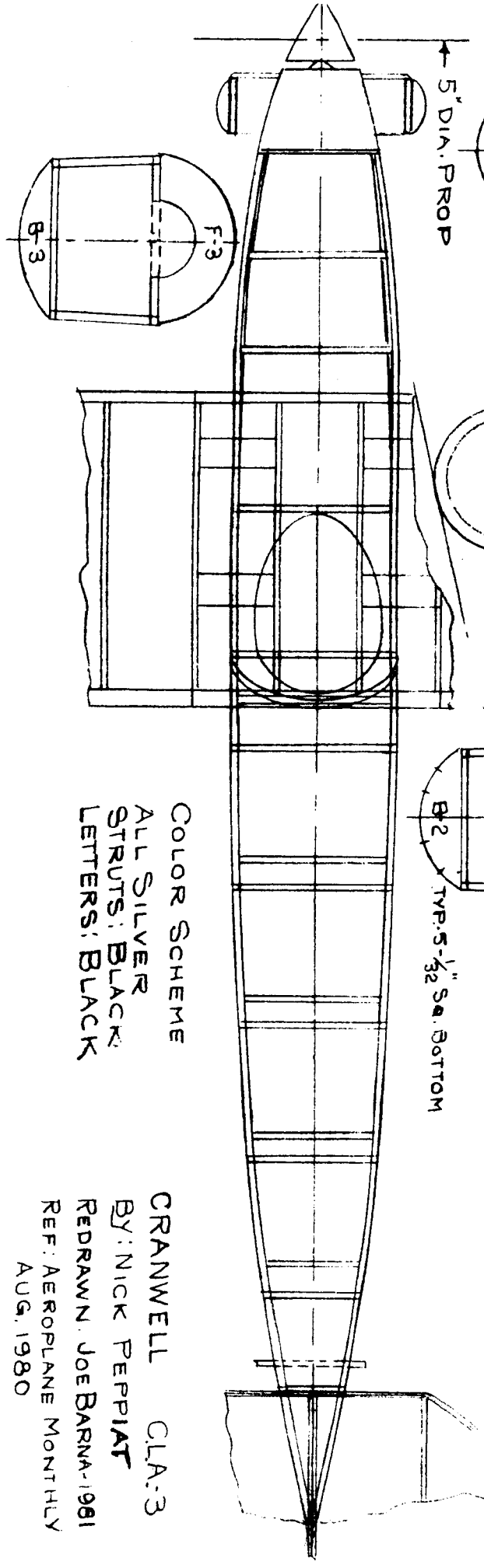

COLOR SCHEME
ALL SILVER
STRUTS: BLACK
LETTERS: BLACK

CRANWELL CLA:3
BY: NICK PEPIAT
REDRAWN: JOE BARNA-1961
REF: AEROPLANE MONTHLY
AUG. 1980

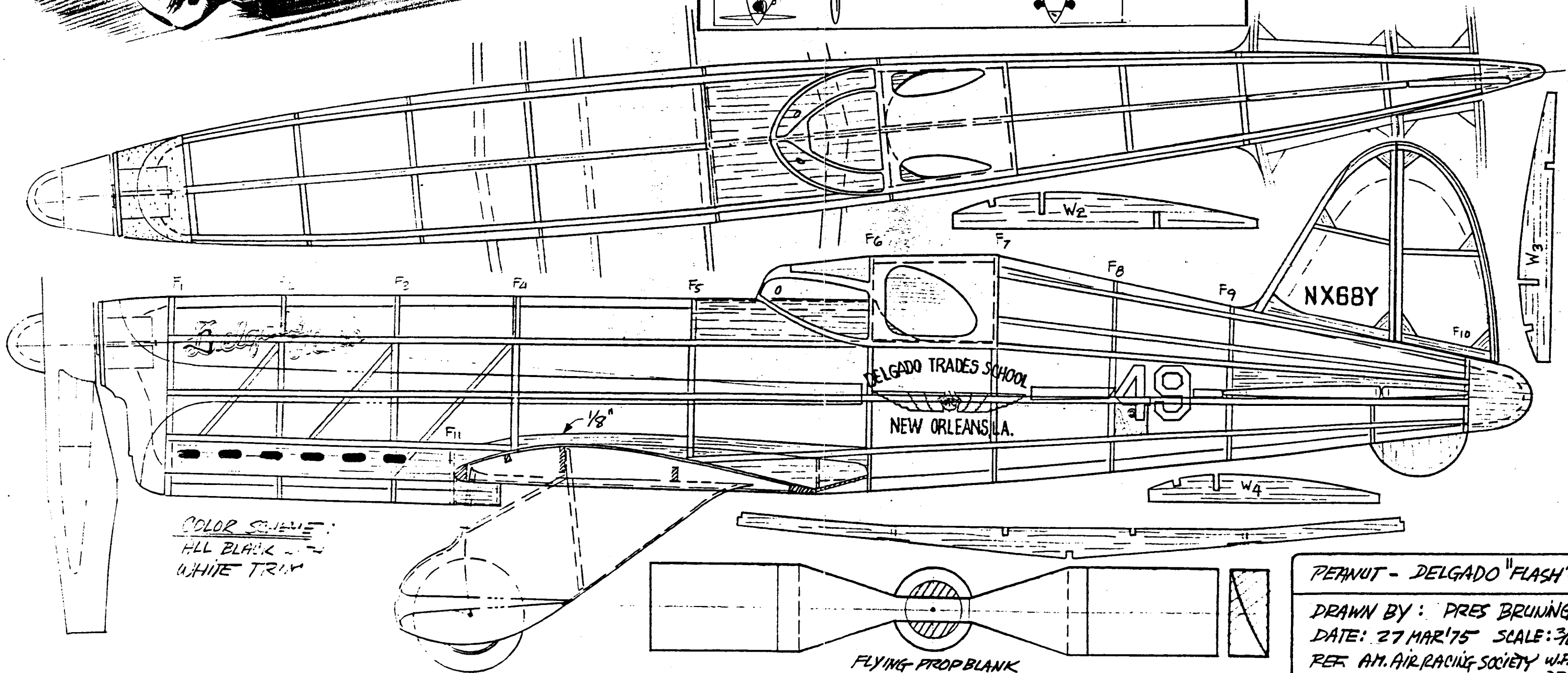
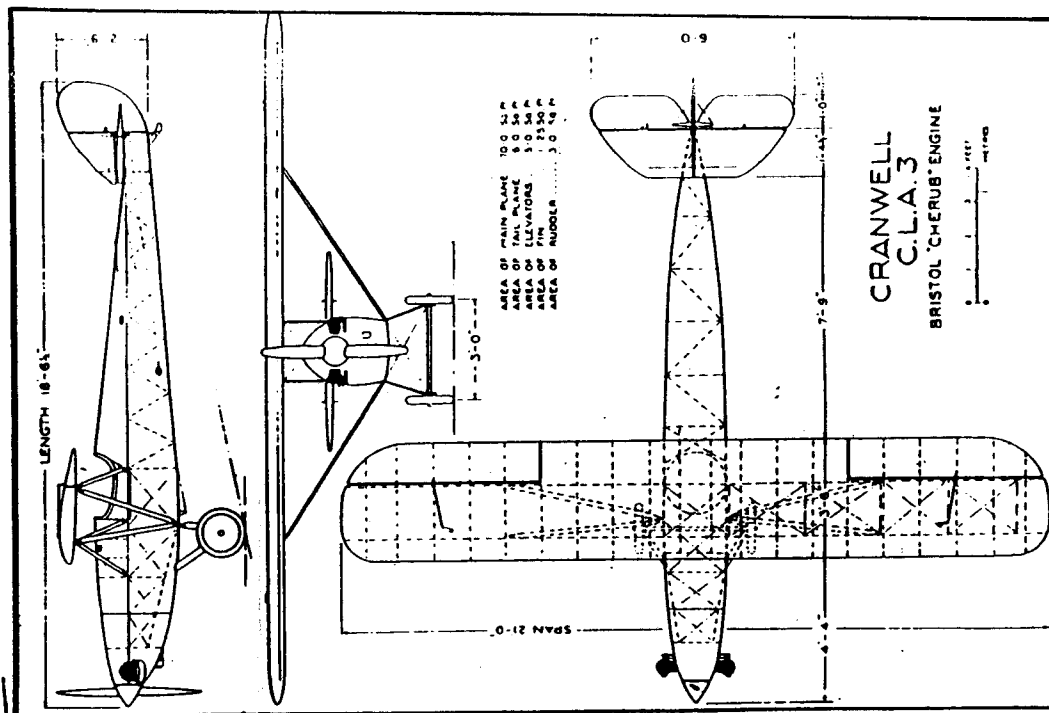

COLOR SCHEME:
 ALL BLACK
 WHITE TRIM

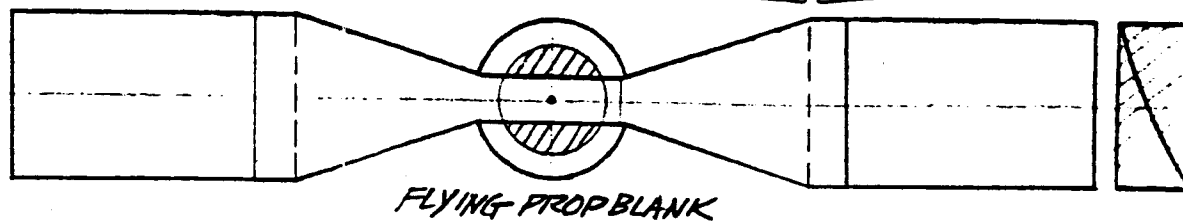

PEANUT - DELGADO "FLASH" - 1938
 DRAWN BY: PRES BRUNING
 DATE: 27 MAR '75 SCALE: 3/4" = 1'
 REF. AM. AIR RACING SOCIETY W.F. KERKA
 DRWG.

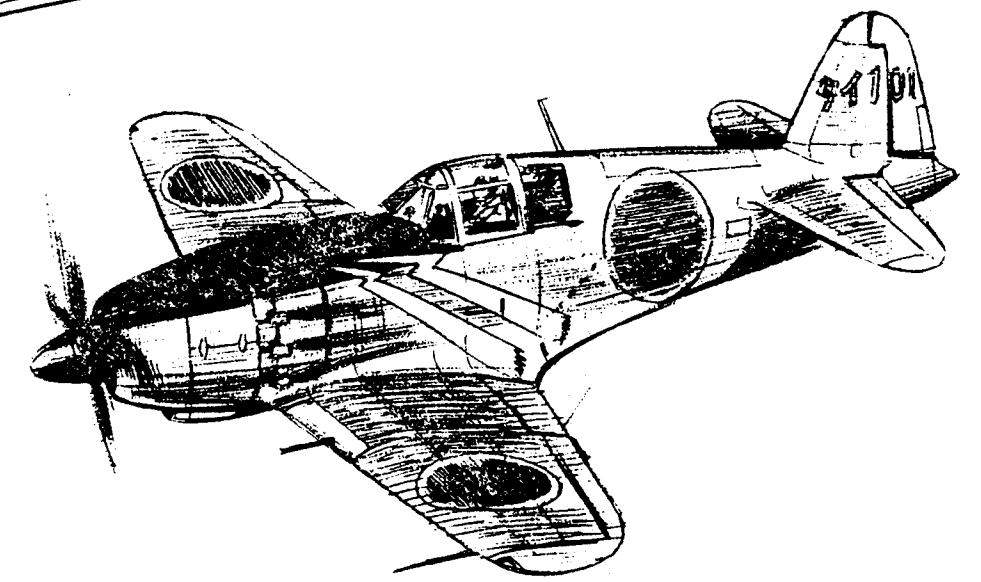
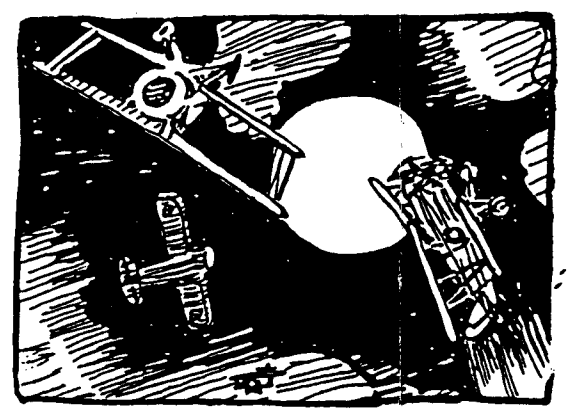
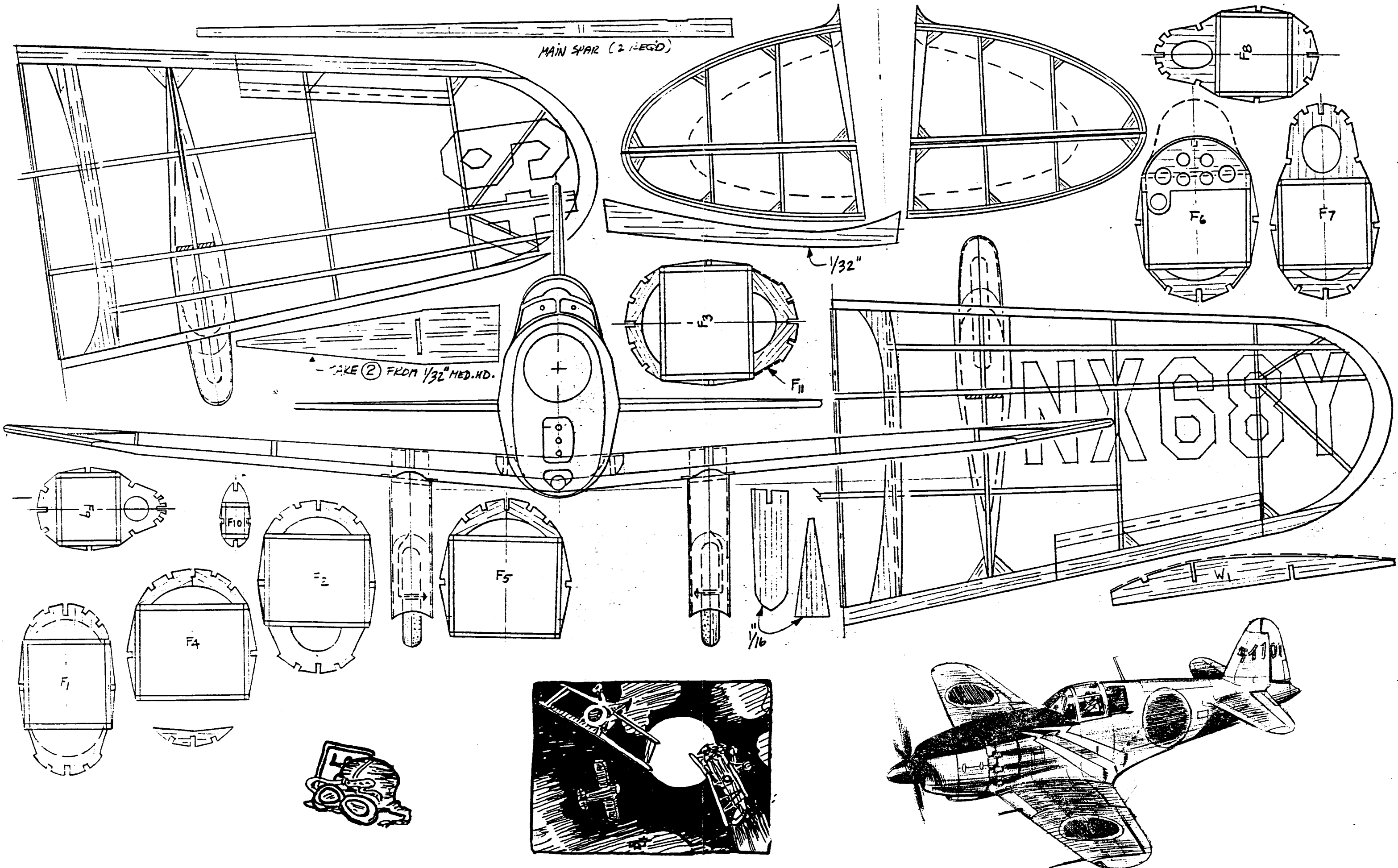

BLACK: ALL WING + CABANE STRUTS

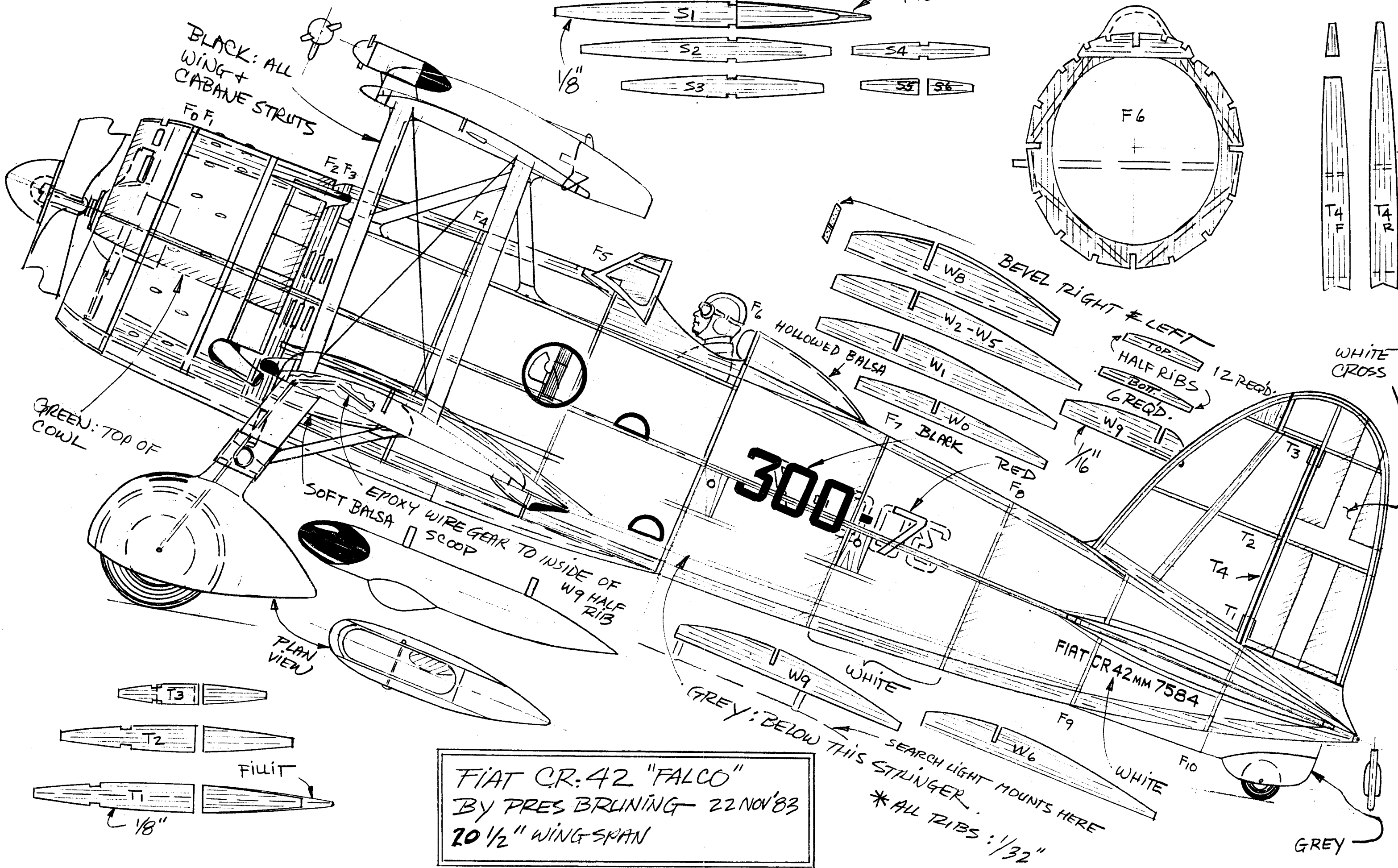
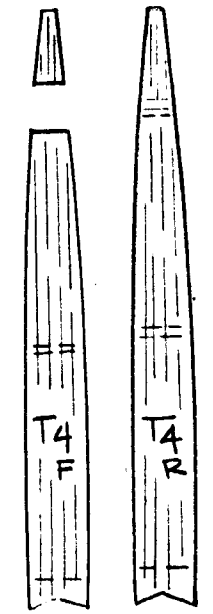
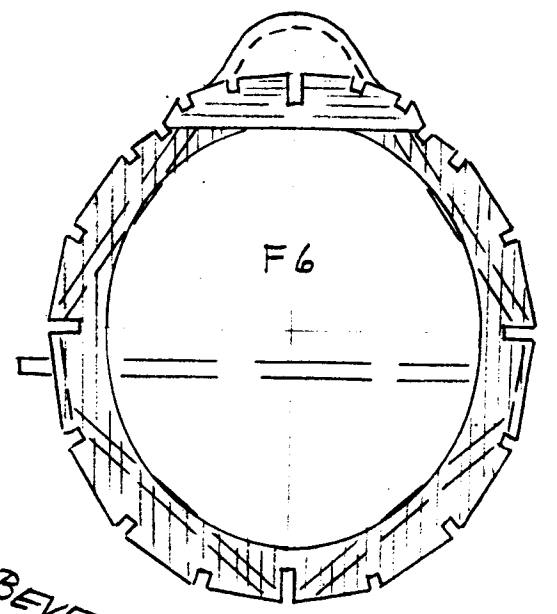
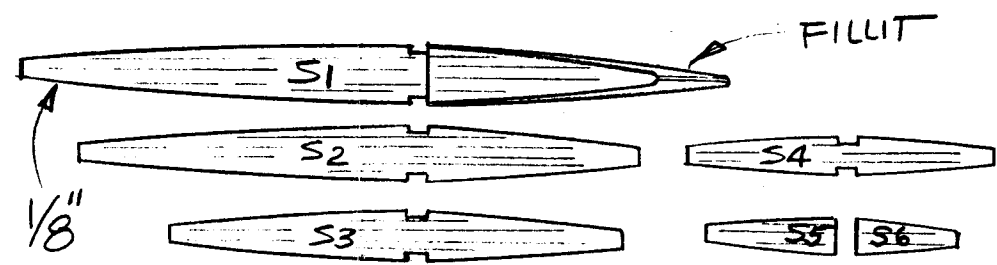

GREEN: TOP OF COWL

EPOXY WIRE GEAR TO INSIDE OF W9 HALF RIB
SOFT Balsa SCOP

HOLLOWED Balsa

BEVEL RIGHT & LEFT

TOP HALF RIBS 12 REQD.
BOT. 6 REQD.

WHITE CROSS

FIAT CR42MM 7584

SEARCH LIGHT MOUNTS HERE
* ALL RIBS : 1/32"

FIAT CR:42 "FALCO"
BY PRES BRUNING 22 NOV '83
20 1/2" WING SPAN

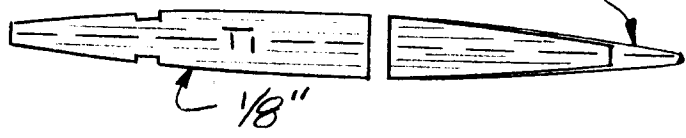
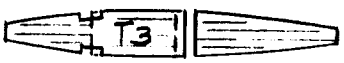

FILLET

1/8"

PLAN VIEW

GREY

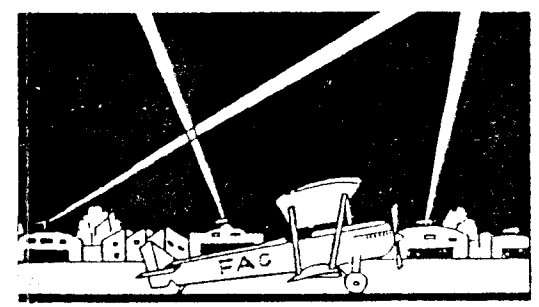
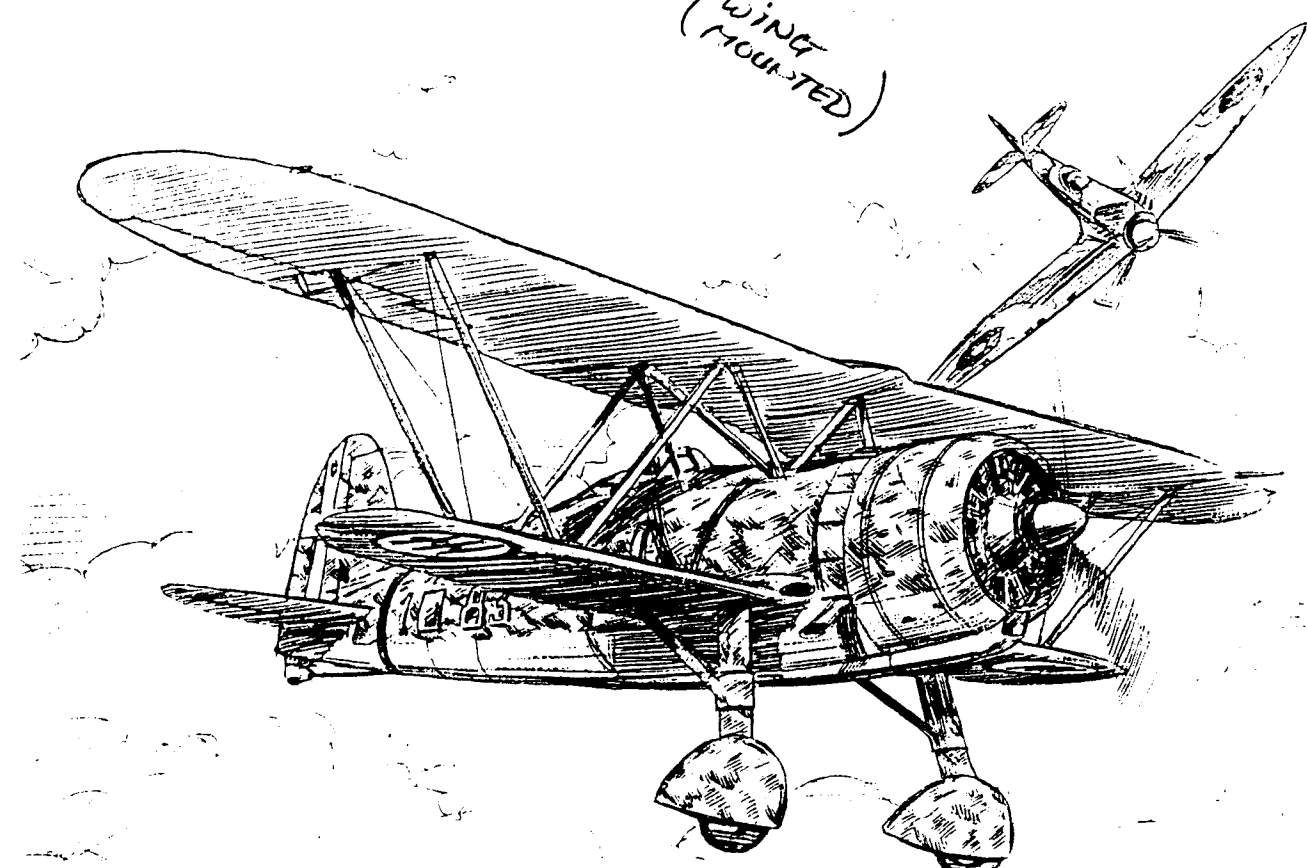
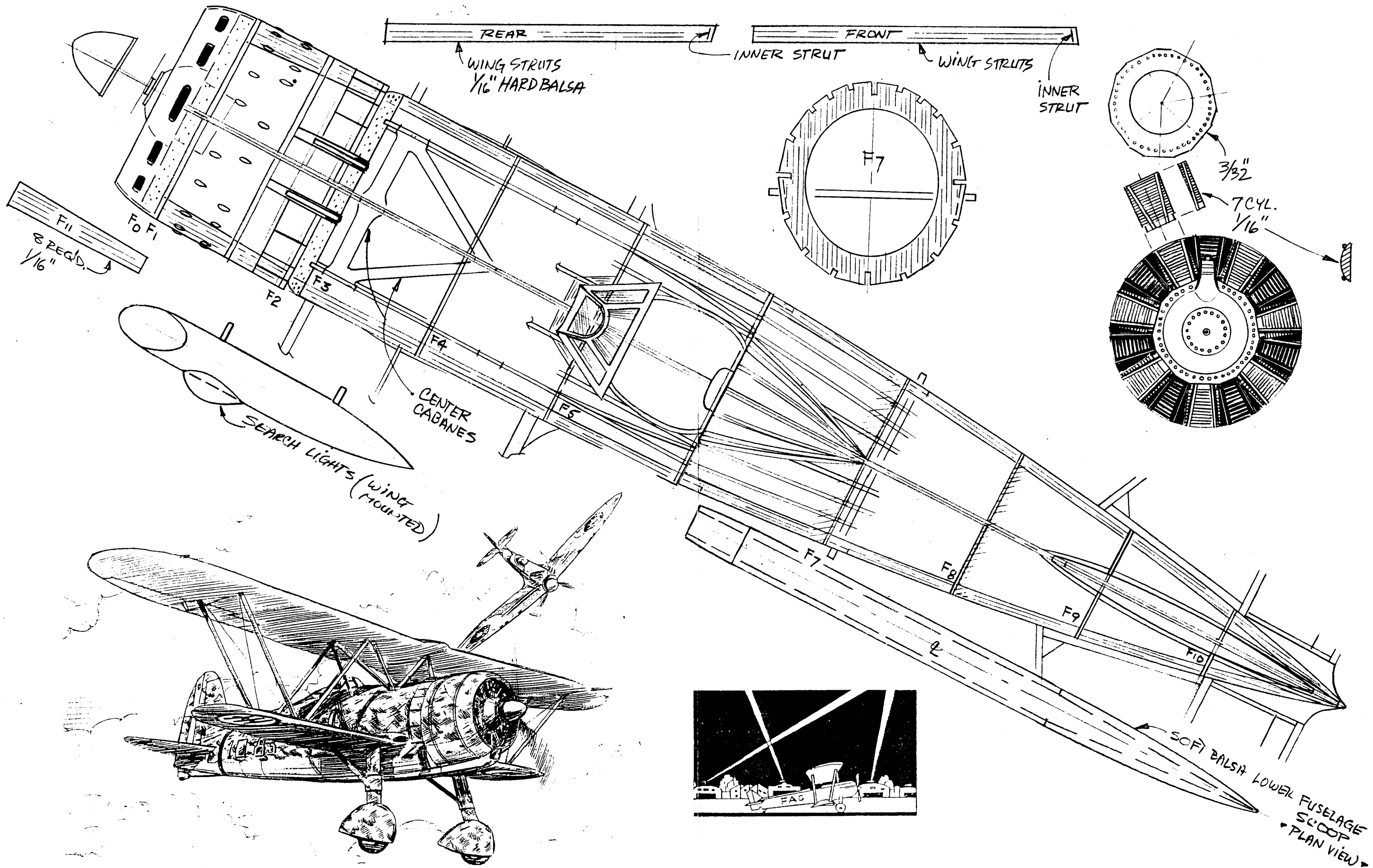

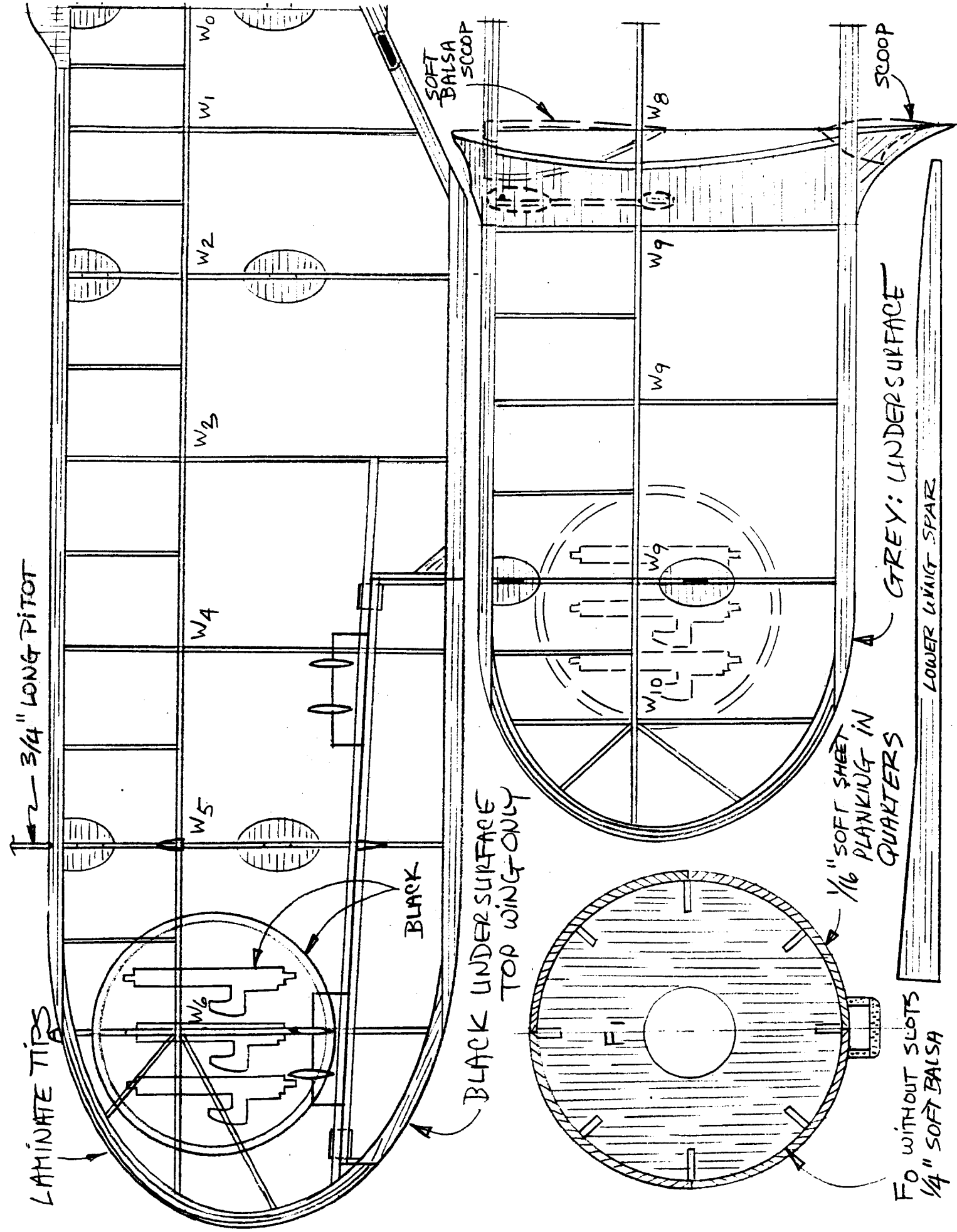
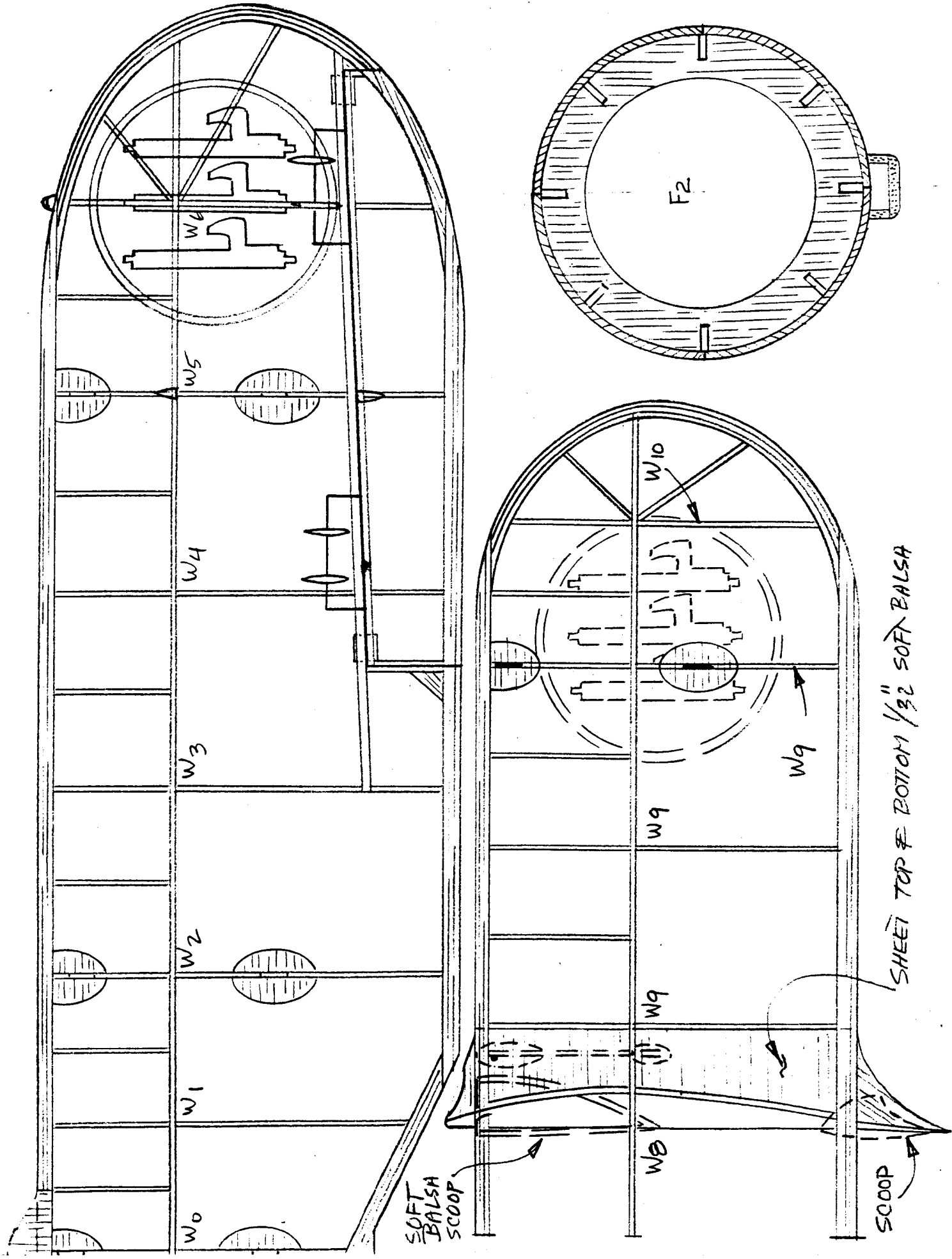

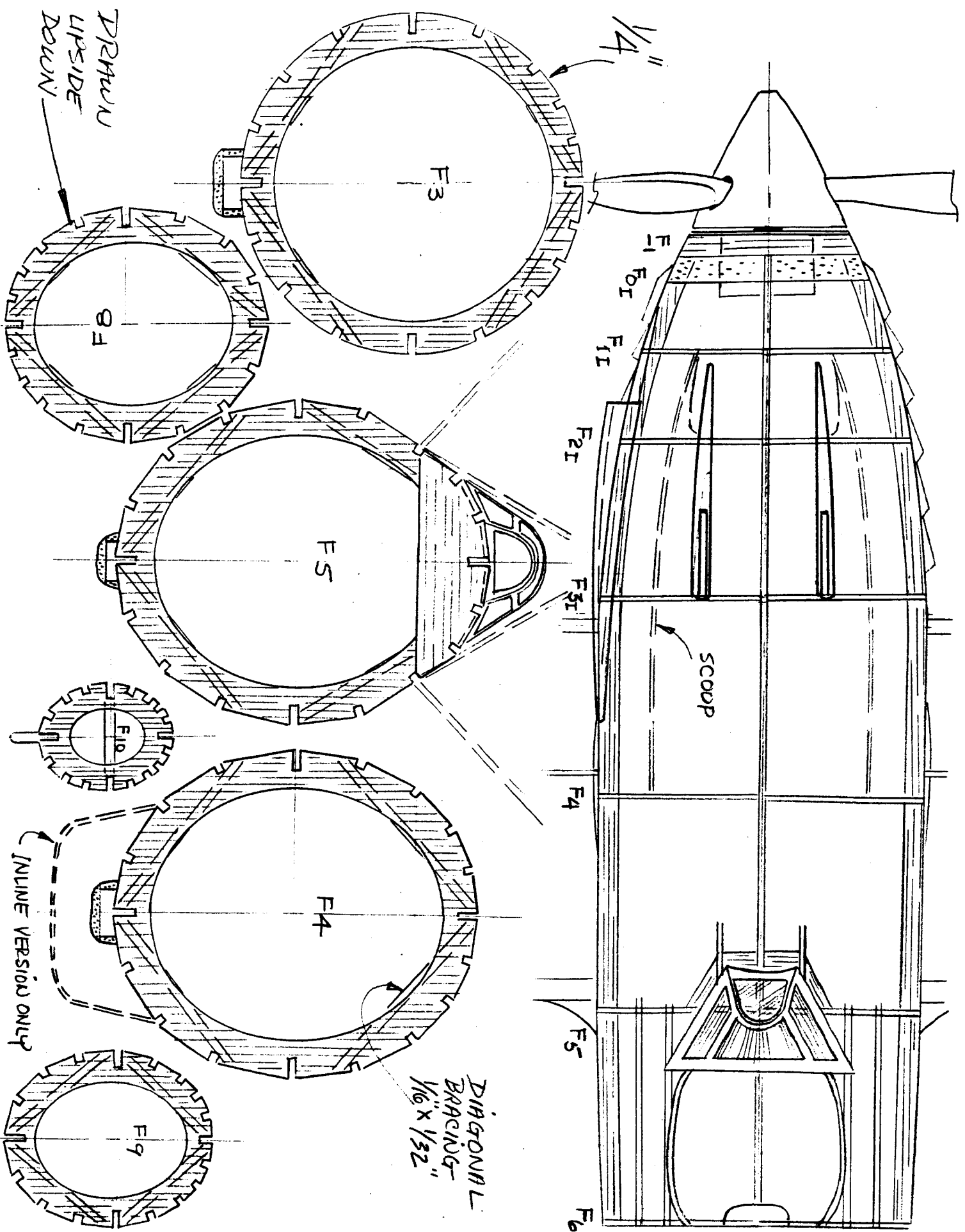
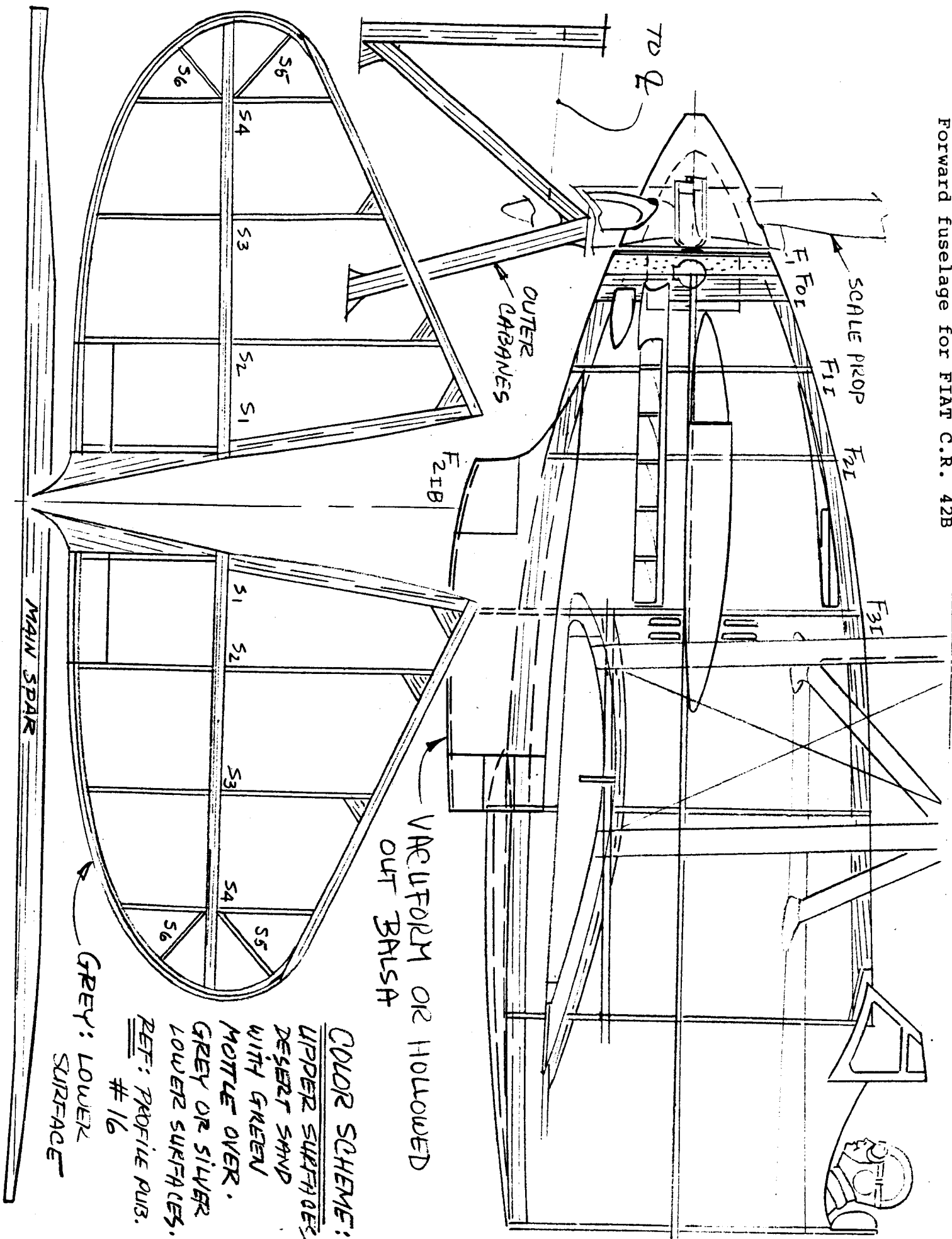

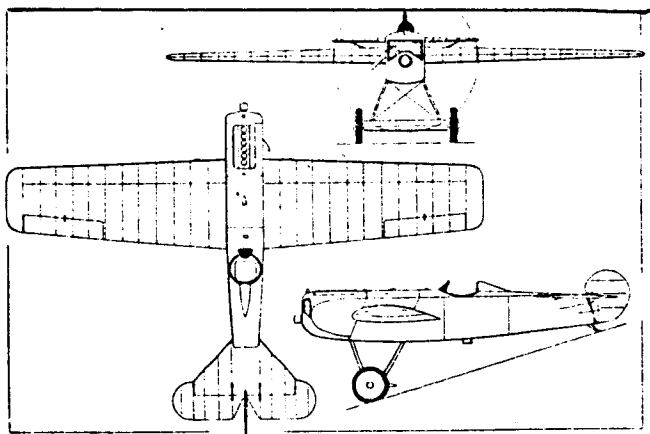
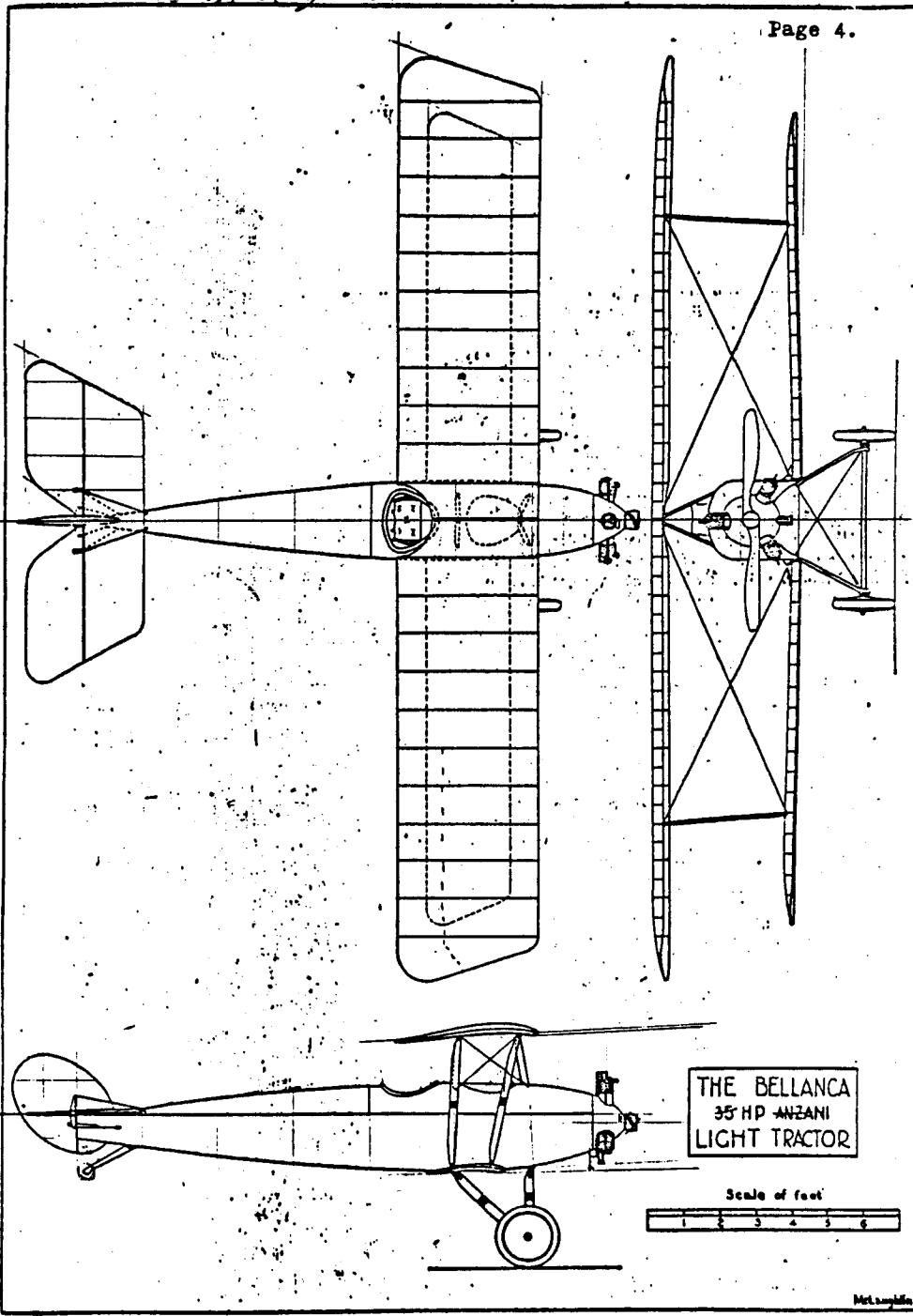

Three-view (above) and photograph of the Fokker V 21, one of the prototype monoplanes entered by Fokker in the second D-type competition in May-June 1918. The V 23 was similar but had untapered wings.

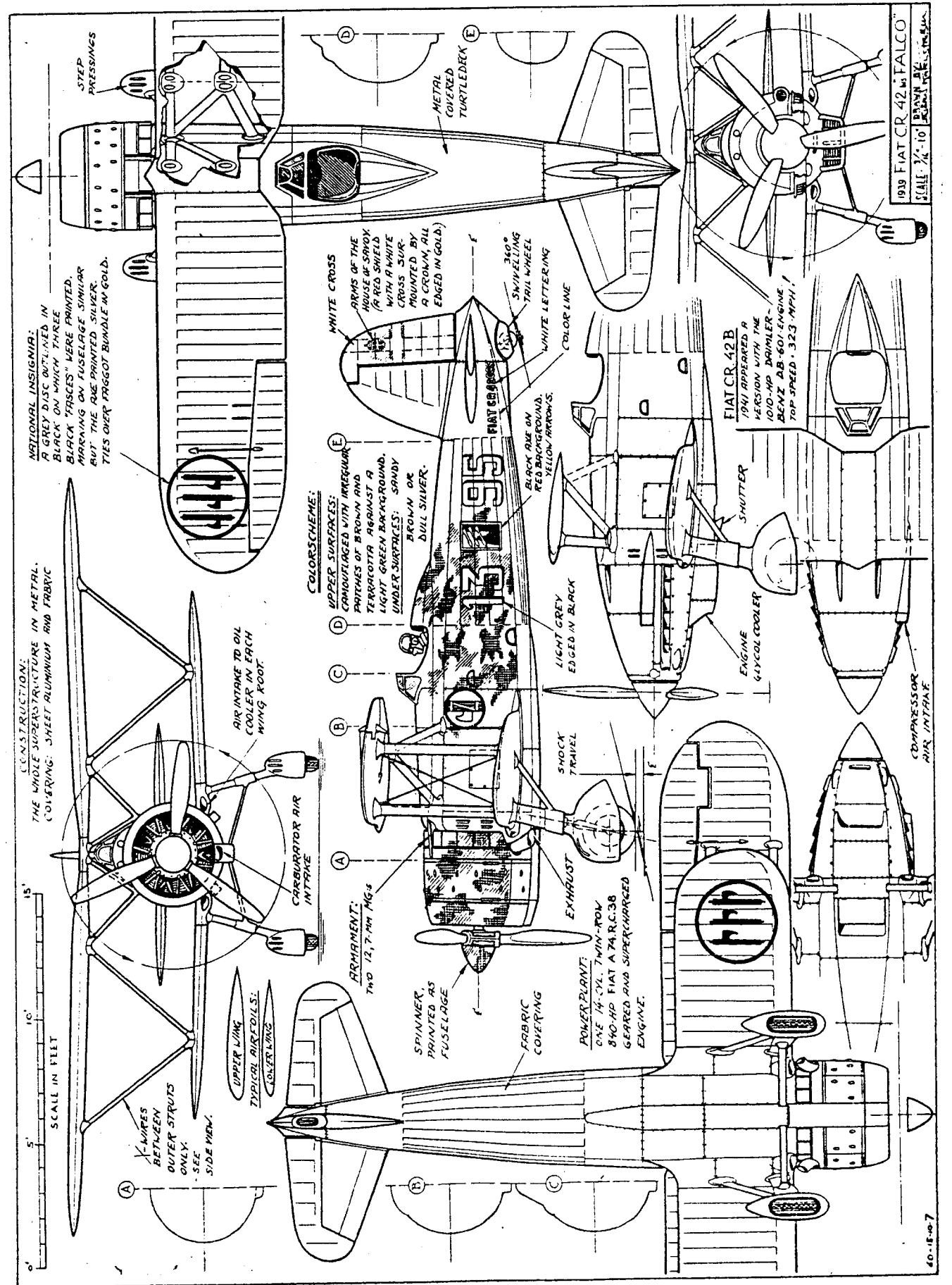
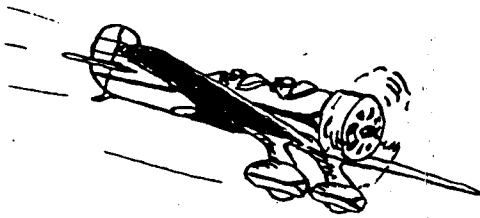
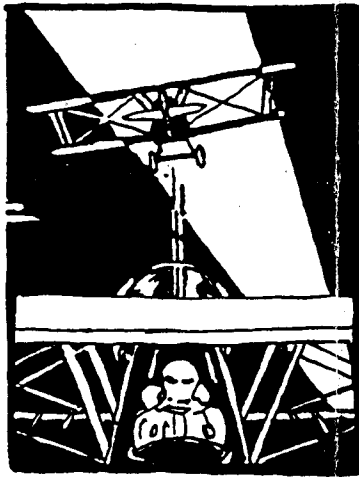

A FLYING ACES CLUB PLAN

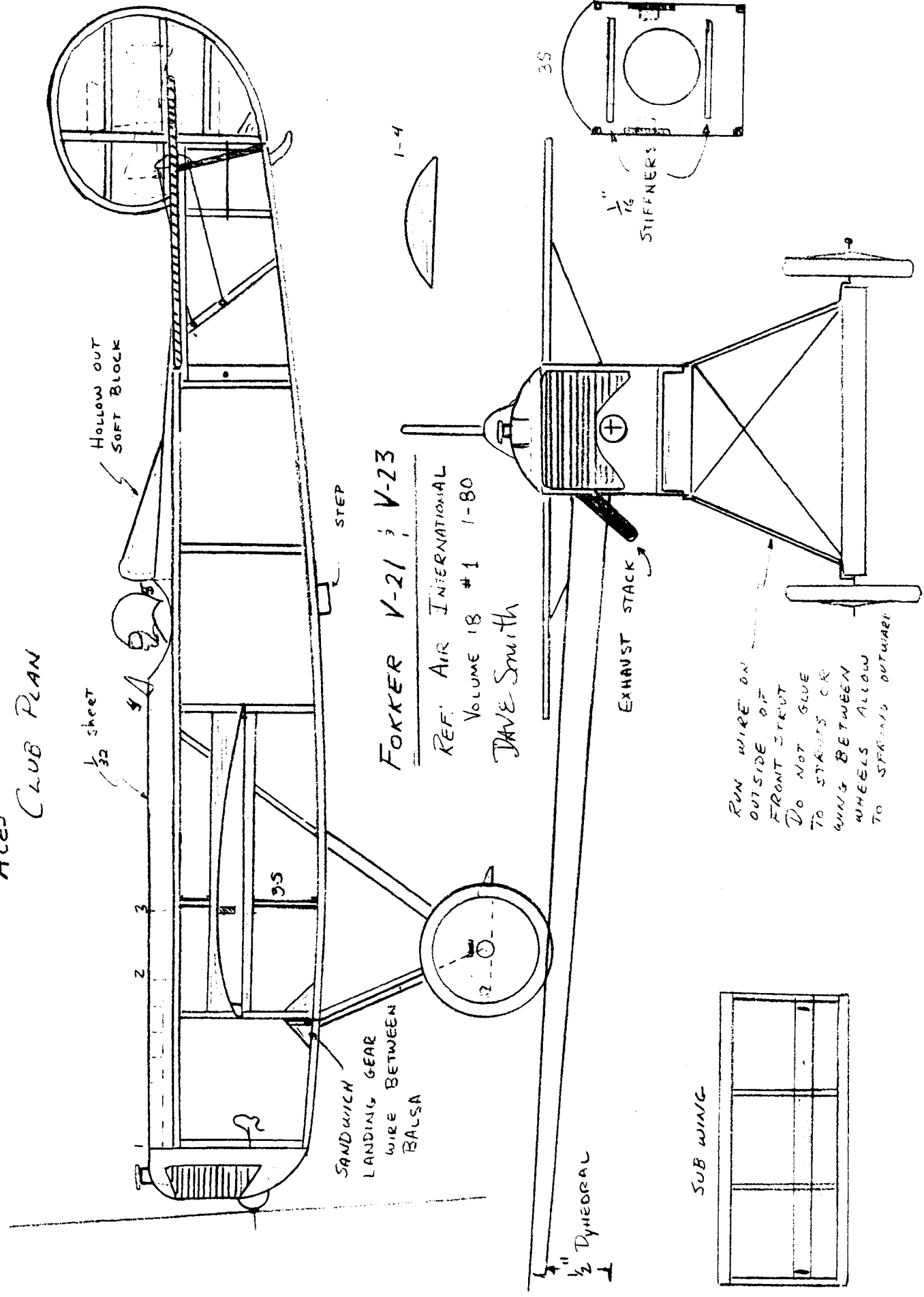

FOKKER V-21 ; V-23
 REF: AIR INTERNATIONAL
 VOLUME 18 #1 1-80
 DAVE SMITH

RUN WIRE ON
 OUTSIDE OF
 FRONT STRUT
 DO NOT GLUE
 TO STRUTS OR
 WING BETWEEN
 WHEELS ALLOW
 TO SPRING OUTWARD

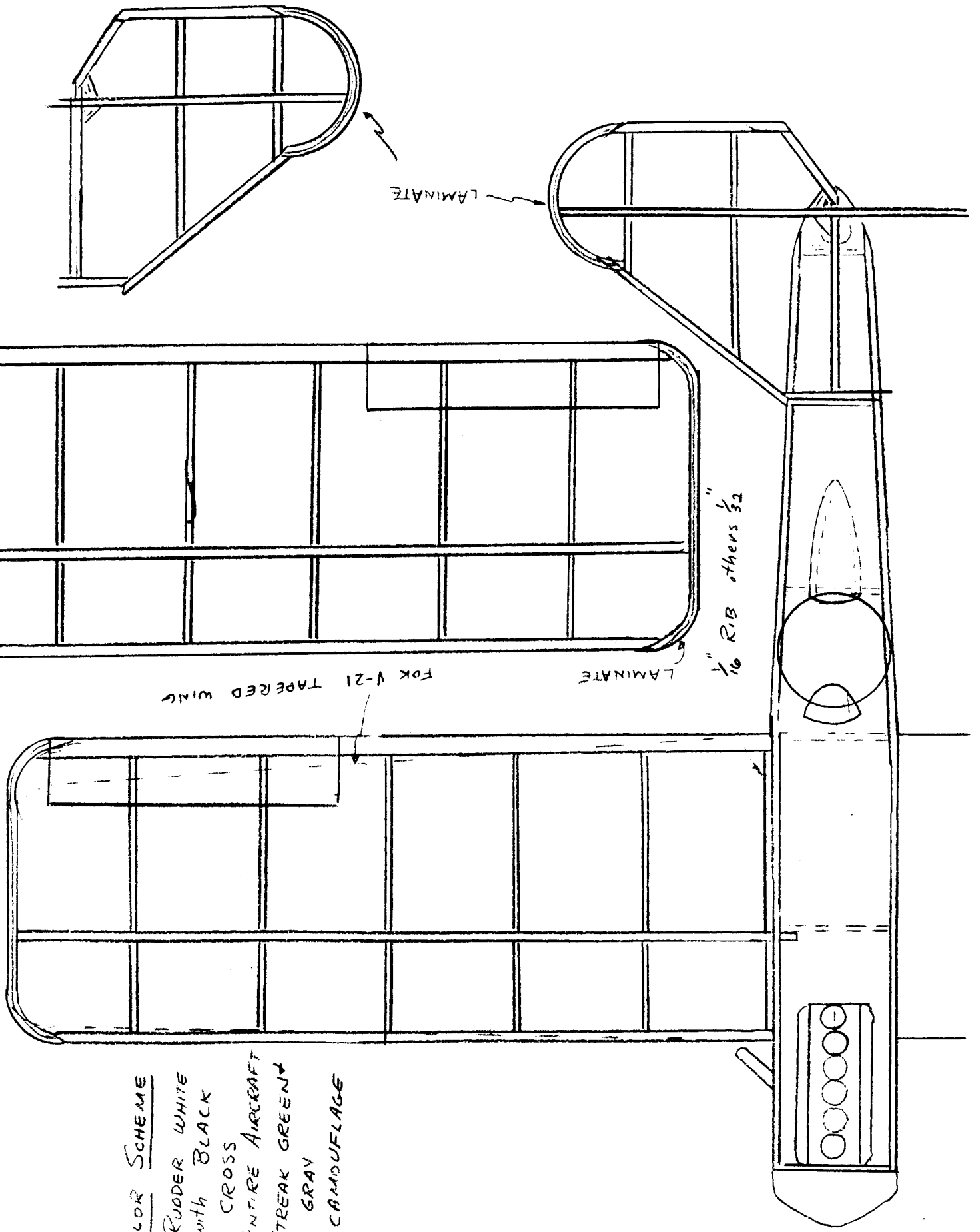
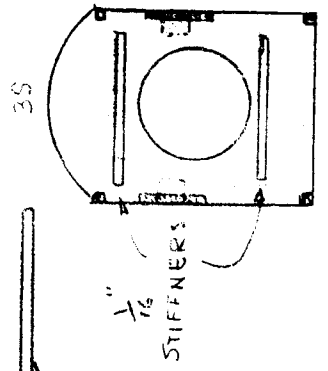
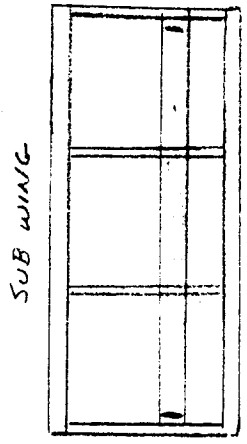

COLOR SCHEME
 RUDDER WHITE
 with BLACK
 CROSS
 ENTIRE AIRCRAFT
 STREAK GREEN
 + GRAY
 CAMOUFLAGE

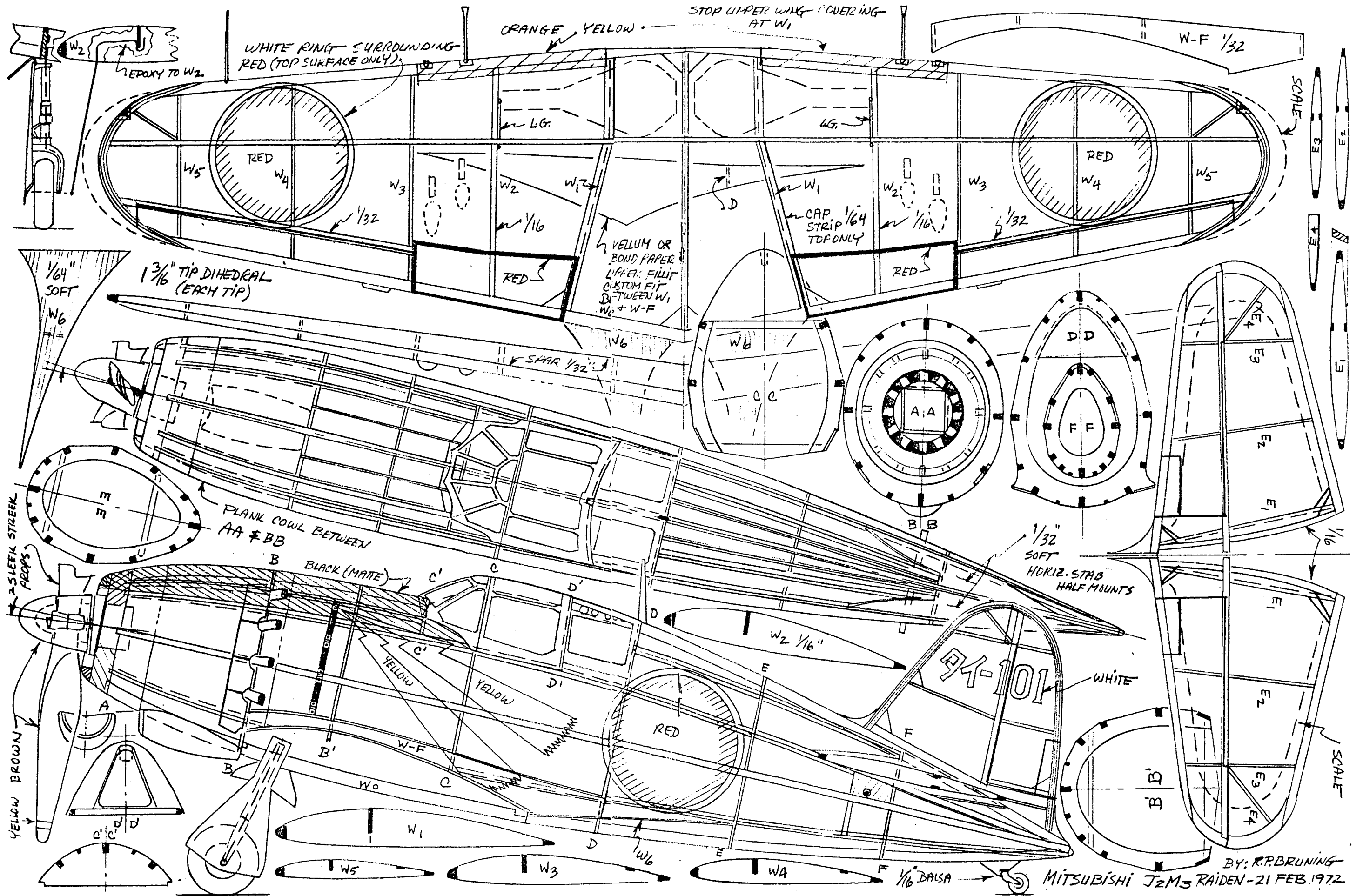

BY: R.P. BRUNING
 MITSUBISHI J2M3 RAIDEN - 21 FEB. 1972

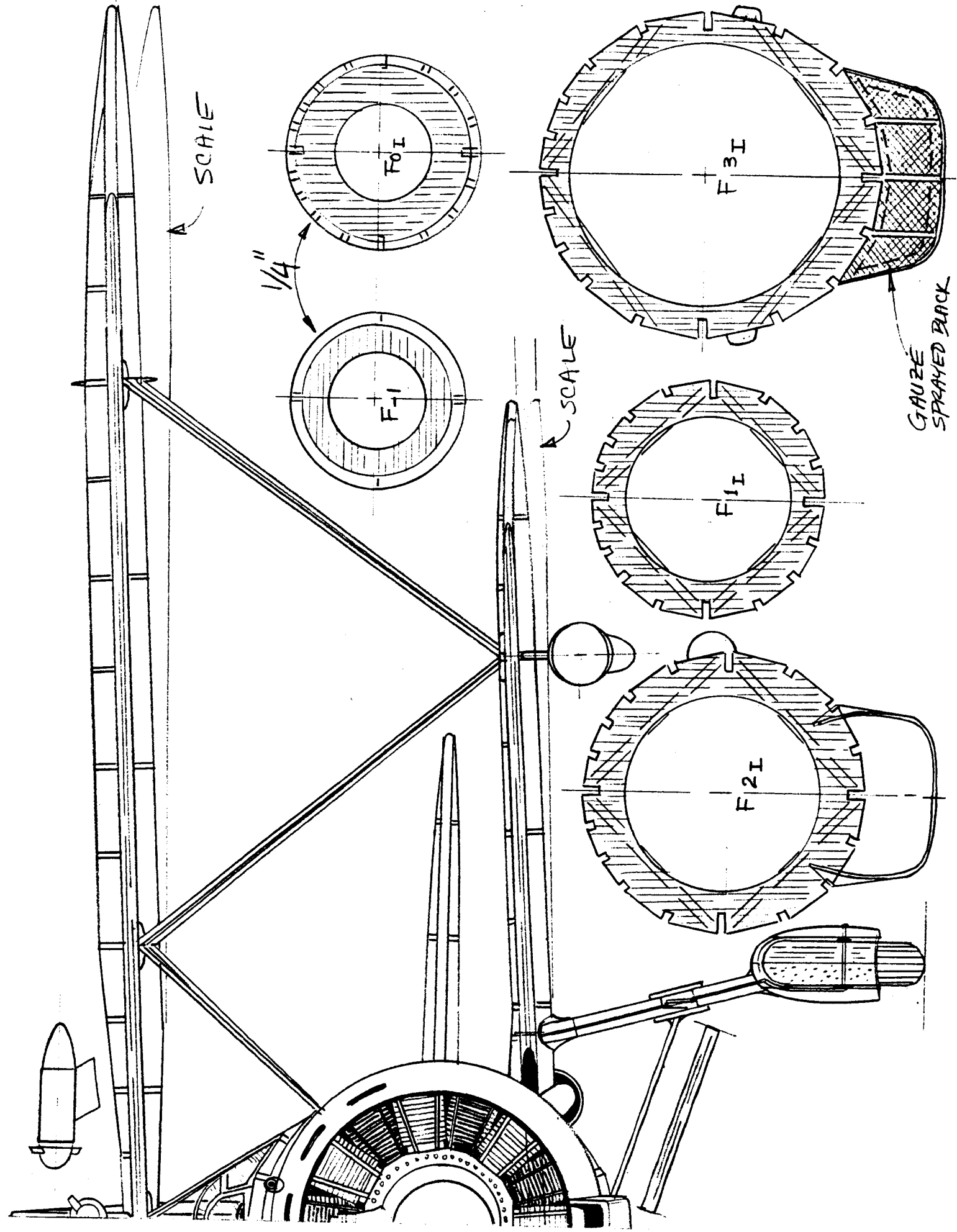
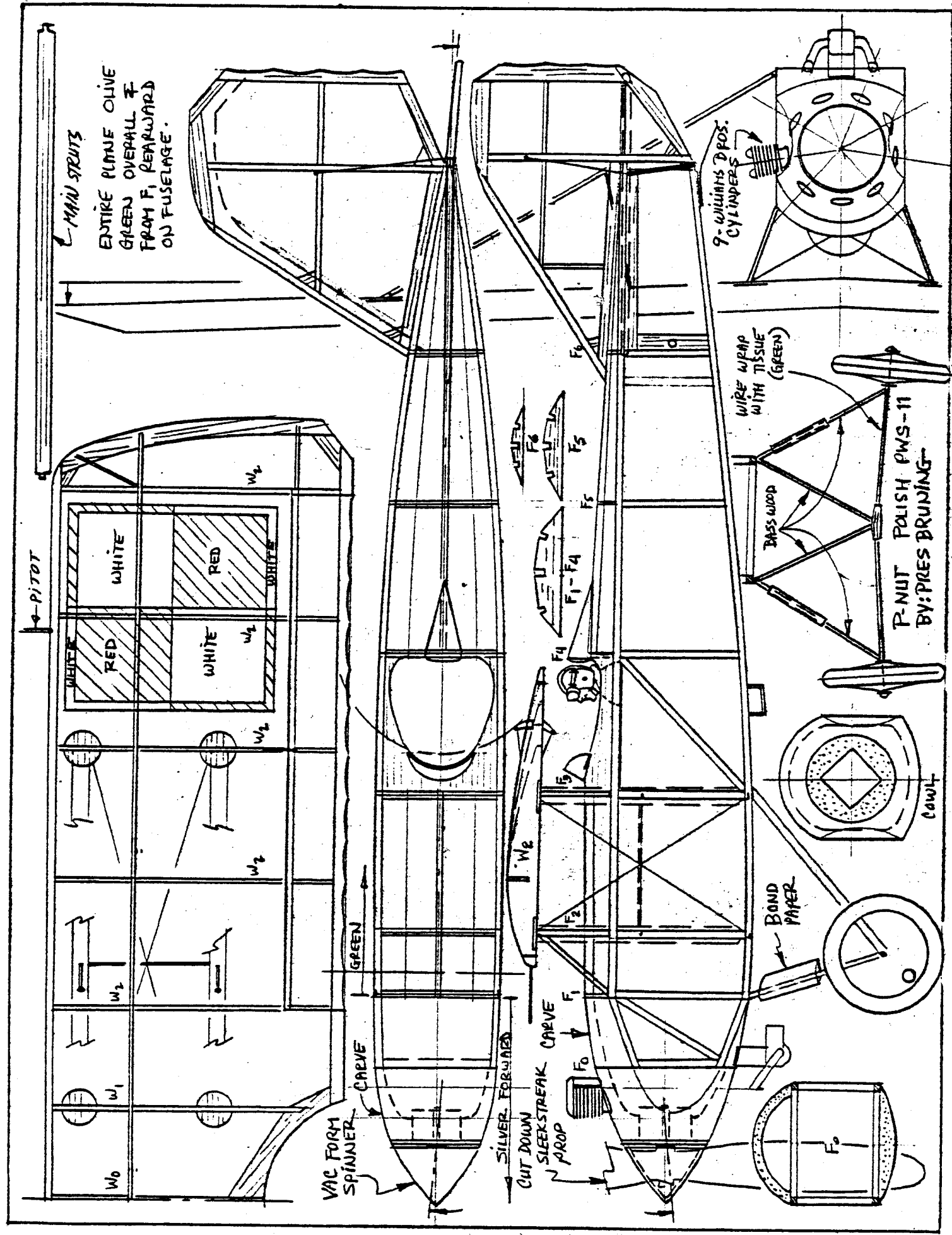

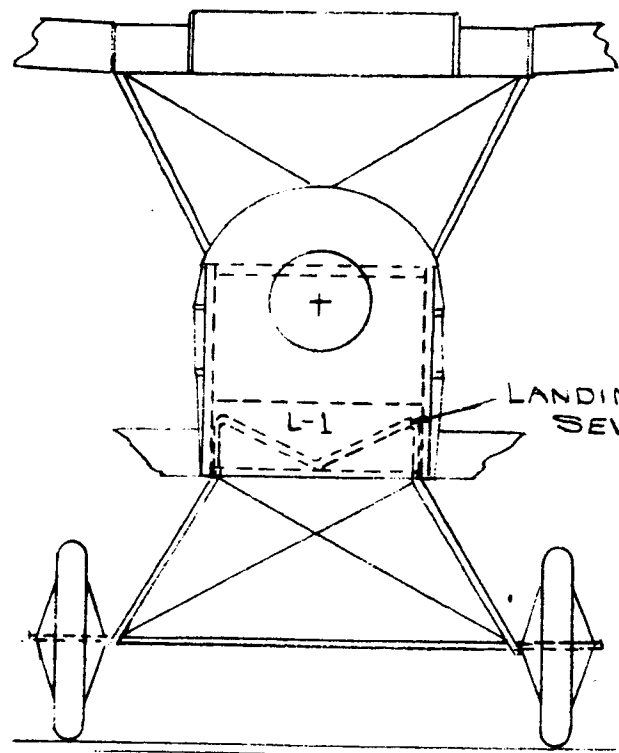

LANDING GEAR .015 MW
SEW TO L-1

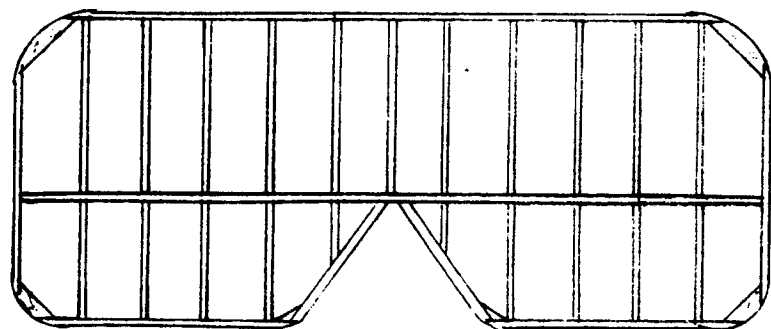

STAB 1/20 SQ. Balsa



INTERPLANE STRUTS

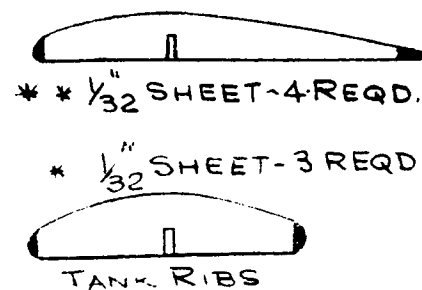

** 1/32 SHEET - 4 REQD.

* 1/32 SHEET - 3 REQD.

TANK RIBS

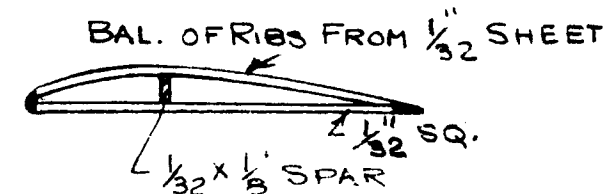

BAL. OF RIBS FROM 1/32 SHEET

2 1/32 SQ.
1/32 x 1/8 SPAR

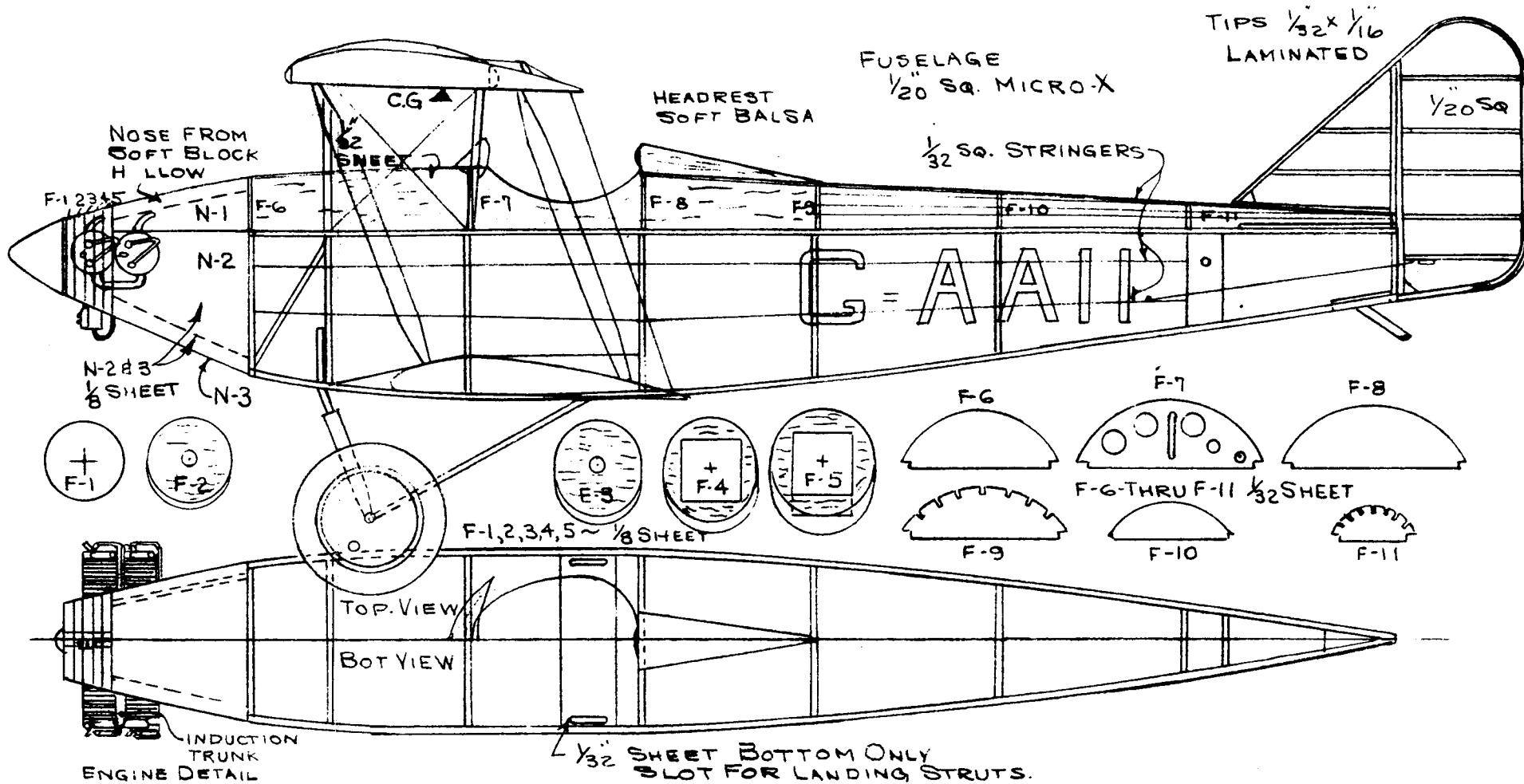

FUSELAGE
1/20 SQ. MICRO-X

TIPS 1/32 x 1/16
LAMINATED

HEADREST
SOFT Balsa

1/32 SQ. STRINGERS

NOSE FROM
SOFT BLOCK
HOLLOW

CG

F-1,2,3,4,5

N-1

F-6

F-7

F-8

F-9

F-10

F-11

N-2,3
1/8 SHEET

N-3

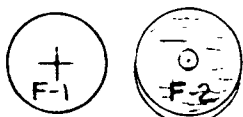

F-1

F-2

F-1,2,3,4,5 ~ 1/8 SHEET

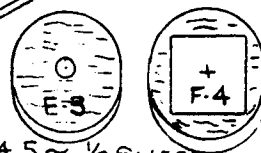

F-3

F-4

F-5

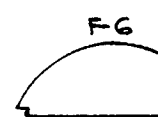

F-6



F-7



F-8

F-6-THRU-F-11 1/32 SHEET

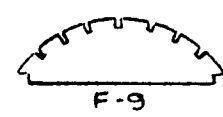

F-9



F-10



F-11

TOP VIEW

BOT VIEW

INDUCTION
TRUNK
ENGINE DETAIL
A.B.C. HORNET
FLAT FOUR

1/32 SHEET BOTTOM ONLY
SLOT FOR LANDING STRUTS.

1/16 x 1/8 LEADING EDGE
ROUNDED

1/32 x 1/16 LAMINATED

NOTE:
SCALE RIB SPACING

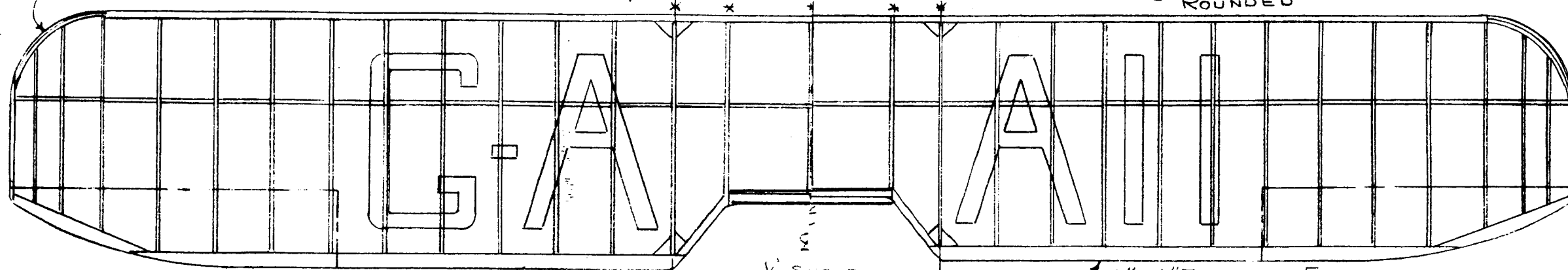

REGISTRATION TOP &
BOTTOM PANELS

DIHEDRAL
BREAK
1/4" EACH TIP

1/16 SHEET
OVER TOP
SECTION
FUELTANK

1/16 x 1/8 TRAILING EDGE
TAPERED

COLOR SCHEME
ALL SILVER w/BLACK
LETTERING -
BLACK CABANE STRUTS
& INTERPLANE STRUTS
REF: AEROPLANE MONTHLY
JULY 80

PEANUT
SOUTHERN MARTLET
SCALE: 1/24
BY: J. WHATMORE
REDRAWN: JOE BARNA
DEC. 1981